

1.0 Reference and Address			
Report Number	SH08120370-001	Original Issued: 19-Jan-2009	Revised: 30-Jun-2020
Standard(s)	Standard for Electric Dry-Bath Heaters [UL 875:2009 Ed.9+R:20Sep2017]		
	Standard for Electric Sauna Heating Equipment [CSA C22.2#164:2018 Ed.2]		
Applicant	HEALTHLAND SAUNA EQUIPMENT CO LTD	Manufacturer	HEALTHLAND SAUNA EQUIPMENT CO LTD
Address	16 FLOOR, TREASURE BUILDING, NO.29, HUAIHAI WEST ROAD, XUZHOU CITY, JIANGSU PROVINCE	Address	HEALTHLAND INDUSTRIAL AREA, NORTH DISTRICT, XUZHOU CITY, JIANGSU PROVINCE
Country	P. R. China	Country	P. R. China
Contact	Mr. Mingtao Zhao	Contact	Mr. Mingtao Zhao
Phone	86- 516-85902726	Phone	86- 516-85902726
FAX	86- 516-85902735	FAX	86- 516-85902735
Email	<a href="mailto:info@healthlandsauna.com">info@healthlandsauna.com</a>	Email	<a href="mailto:info@healthlandsauna.com">info@healthlandsauna.com</a>

2.0 Product Description				
Product	Electric Wooden Dry Sauna			
Brand name	NA			
Description	The products covered in the report are indoor cord-connected Wooden Dry Sauna designed to be installed and used in ordinary dry locations. They are provided with a digital user-operable touch controller for time and temperature setting outdoor.			
Models	HL-200K, HL-400KC			
Model Similarity	these models have same internal room dimension and electrical schematic			
Ratings	120V~, 60Hz, HL-200K: 1600W, HL-400KC:1900W			
Other Ratings	Product	Voltage(V)	Frequency(Hz)	Room dimension approximat (mm)
	HL-200K	120V	60Hz	1200 × 1150 × 1900
	HL-400KC	120V	60Hz	1500×600×1250×1900
Table 1				

**3.0 Product Photographs**

**Photo 1 - Overview (HL-400KC)**



**Photo 2 - Overview (HL-200K)**



**3.0 Product Photographs**

**Photo 3 - Control panel (Note: two panels are employed which located inside & outside the door)**



**Photo 4 - Outside lamp and main switch on the eave**



**3.0 Product Photographs**

**Photo 5 - Internal lamp on the ceiling**



**Photo 6 - Inlet ventilation**



6

### 3.0 Product Photographs

Photo 7 - Wooden handle, the door open outward



Photo 8 - Magnetic catcher for door



### 3.0 Product Photographs

Photo 9 - Internal view (Note: all seats cannot be opened without aid of tool)



Photo 10 - Top View (Note: All wire to heaters are enclosed by metal conduit. A wooden cover enclosed all parts on the ceiling, which is fixed by screws)



**3.0 Product Photographs**

**Photo 11 - Internal control panel**



**Photo 12 - Control box**

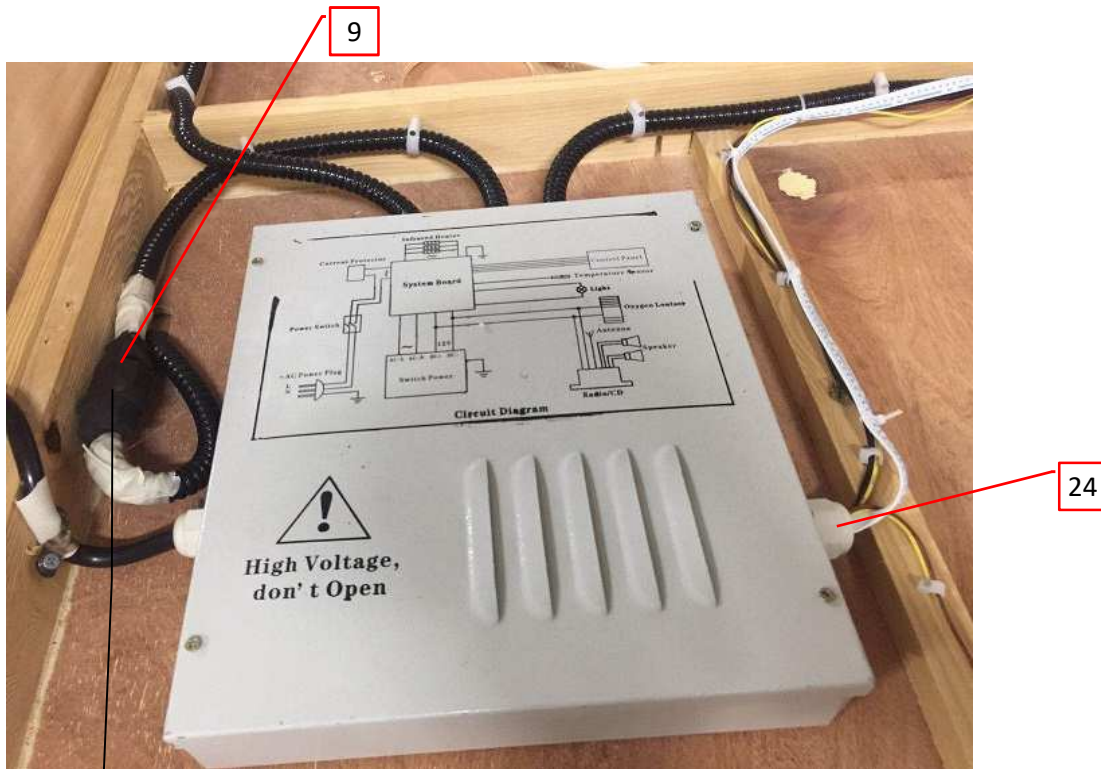

8

**3.0 Product Photographs**

**Photo 13 - Control box (HL-400KC)**

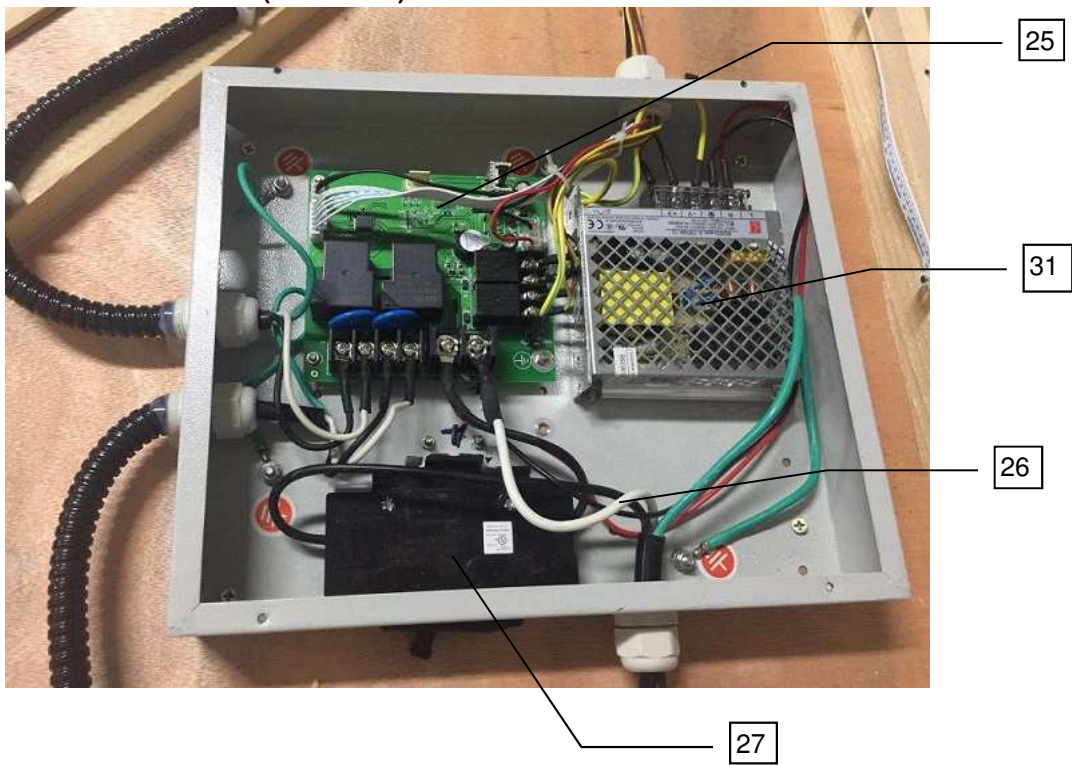

**Photo 14 - Control Box (HL-200K)**

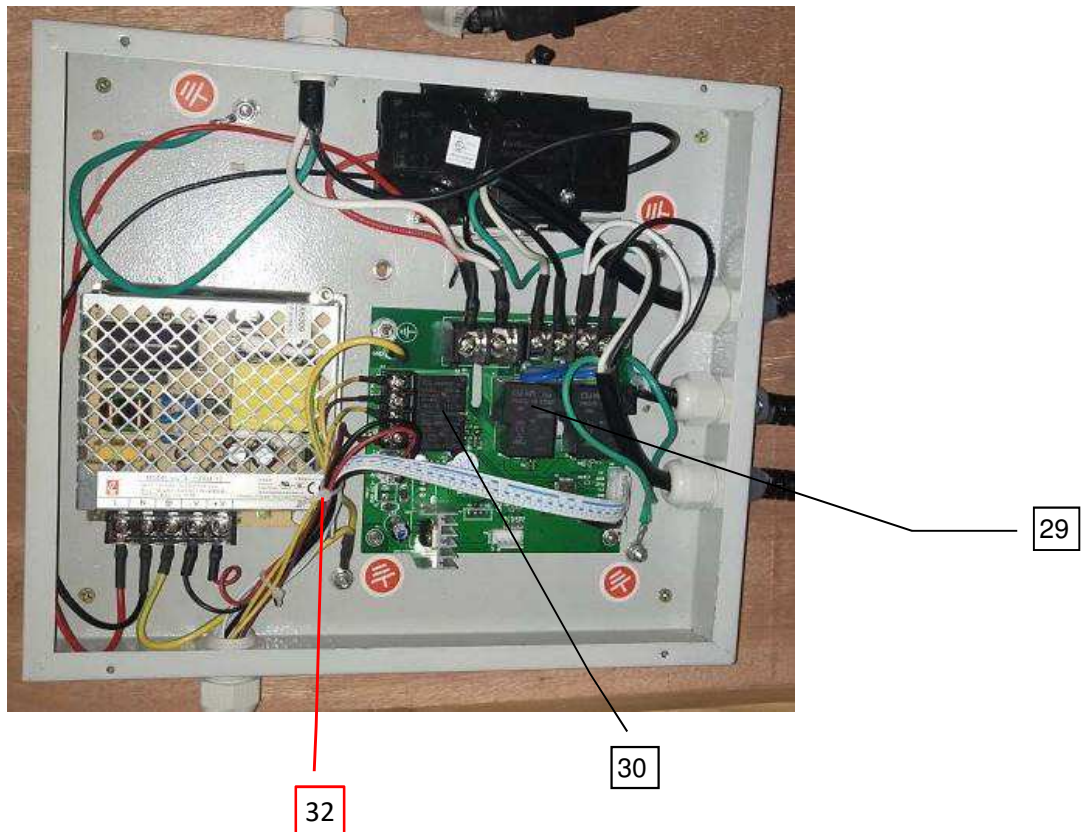

**3.0 Product Photographs**

**Photo 15 - Cord anchorage**



**Photo 16 - Cord and Connection under seat, which cannot be contact without aid of tool, the interconnection cord is enclosed by metal conduit**



3

### 3.0 Product Photographs

**Photo 17 - Heater (Note: the thermostat & thermal link are fixed by wooden block & insulated tape, The side to heater of the wood is enclosed by three layers insulated tape to limit the temperature during normal operation.)**

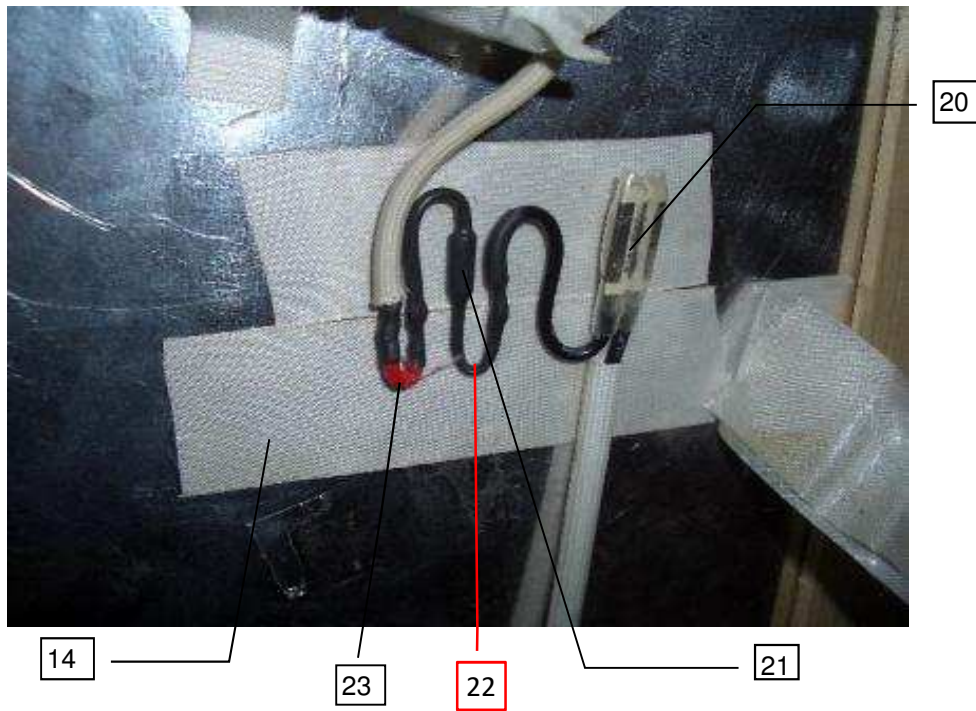

**Photo 18 - Heater**



**3.0 Product Photographs**

**Photo 19 - Thermostat & thermal link**



**Photo 20 - Terminal box for heater connection**

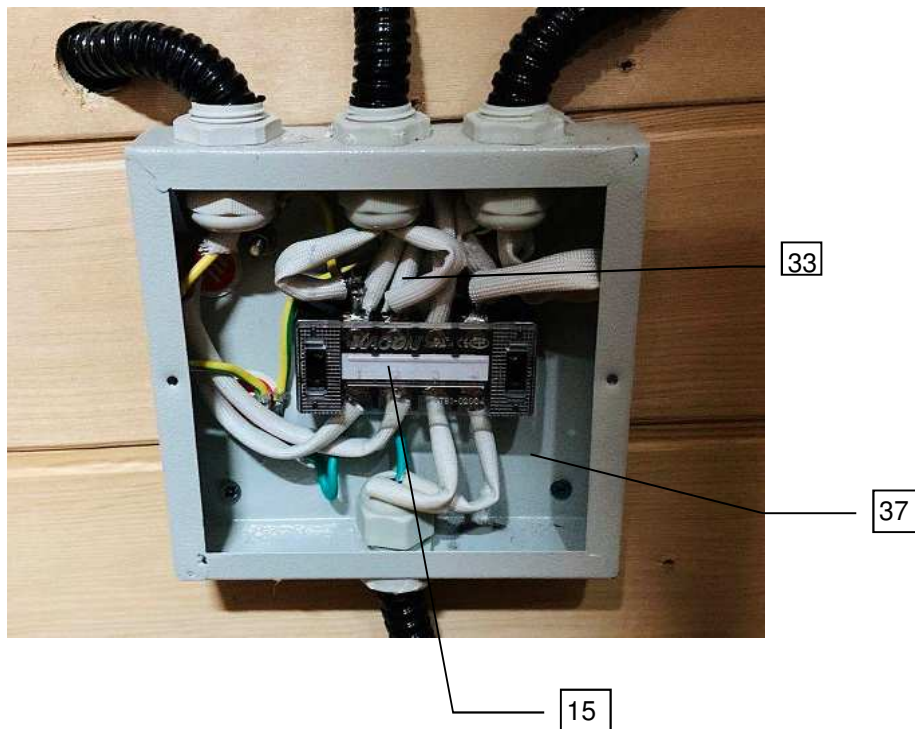

**3.0 Product Photographs**

**Photo 21 - Earthing terminal in the main control box**



**Photo 22 Temperature sensor and wooden guard (HL-400KC)**

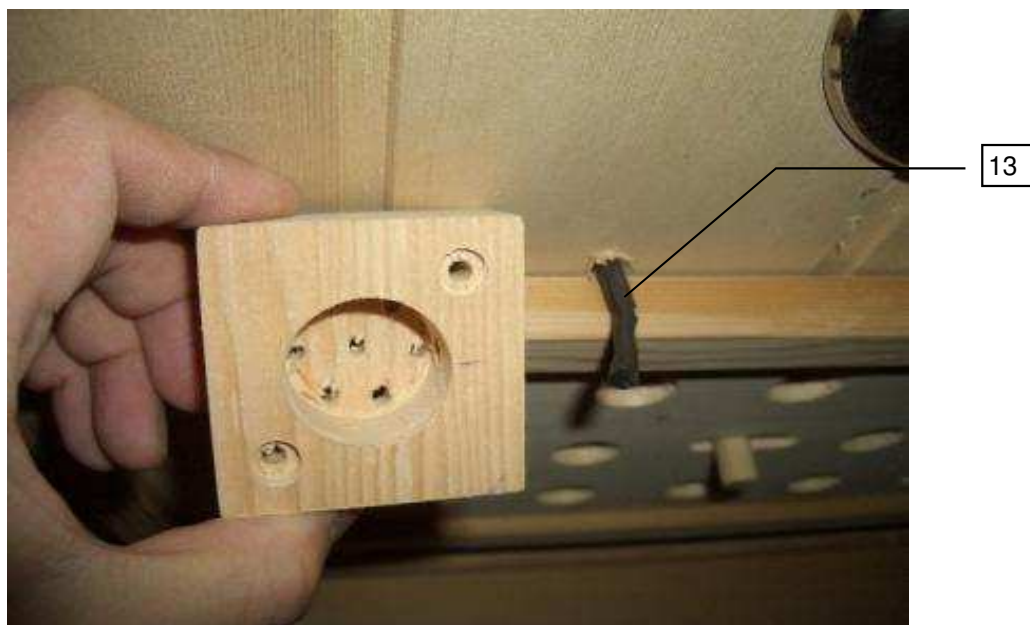

### 3.0 Product Photographs

Photo 23 Heater

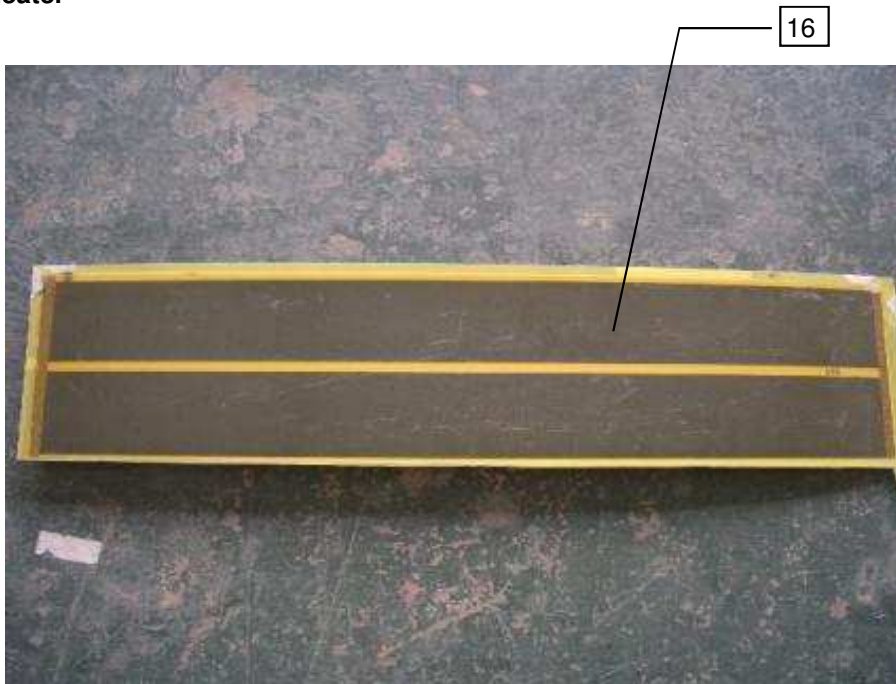
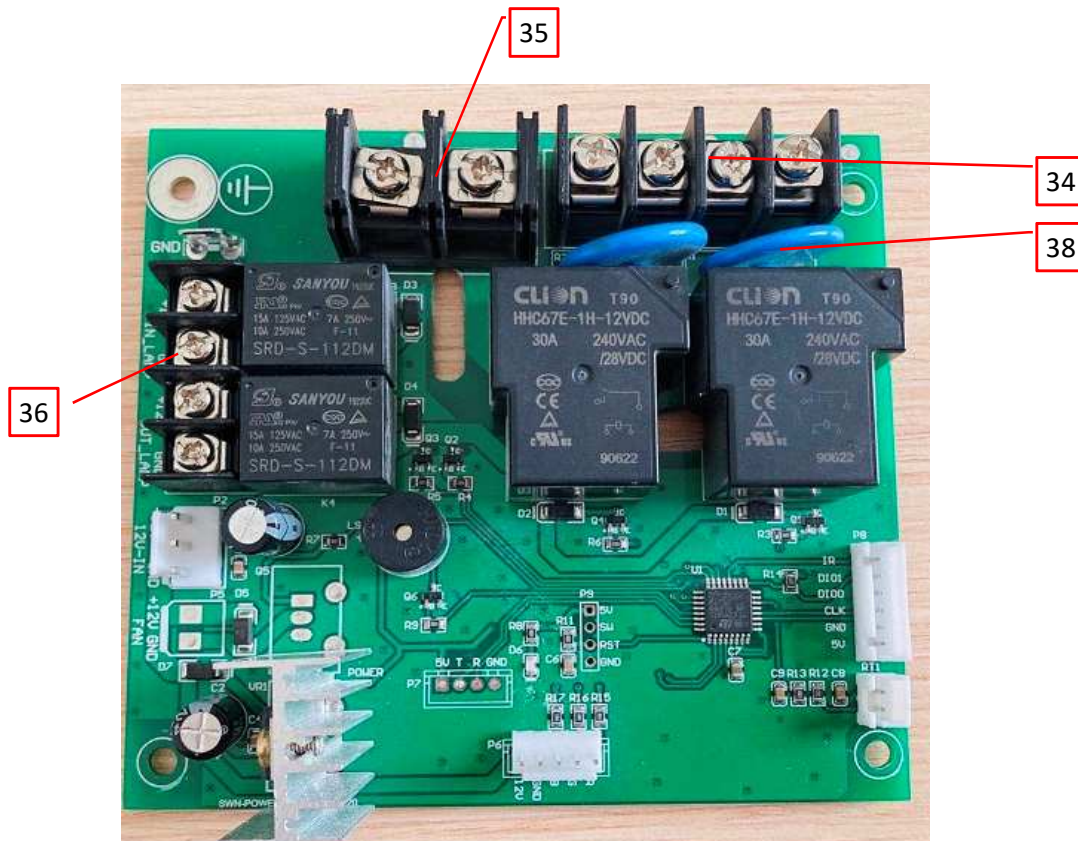
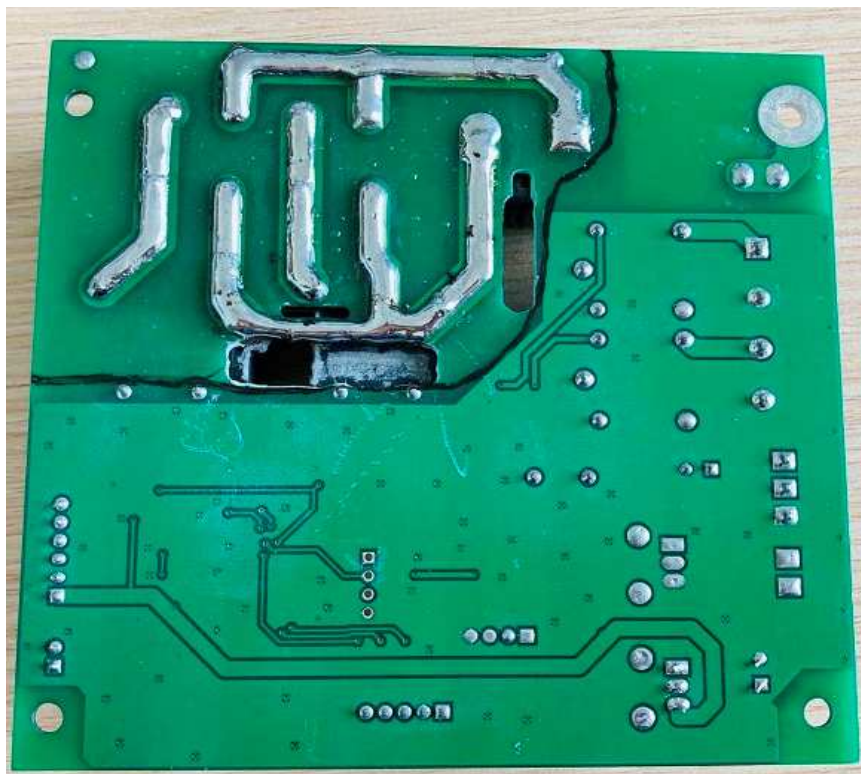

Photo 24 - PCB



### 3.0 Product Photographs

**Photo 25 - PCB** (Note: The Low-voltage circuits are separated from the Line-voltage circuits at least 6.4 mm as the black line showed in the photo. The top side is line-voltage circuits and the below side is low-voltage circuit.)



4.0 Critical Components						
Photo #	Item no. <sup>1</sup>	Name	Manufacturer/ trademark <sup>2</sup>	Type / model <sup>2</sup>	Technical data and securement means	Mark(s) of conformity <sup>3</sup>
2	1	Power Cord	SHAOXING LIMA ELECTRIC CO LTD	SJT	300V, 105°C, No. 14AWG×3 One end terminated in molded on the attachment plug cap with grounding pin. 1.8-2.04 m long from the faces of attachment plugs. E309871	UL
			NINGBO LINSHENG ELECTRIC CO LTD	SJT	300V, 105°C, No. 14AWG×3 One end terminated in molded on the attachment plug cap with grounding pin. 1.8-2.04 m long from the faces of attachment plugs. E218475	UL
2	2	Power Plug	SHAOXING LIMA ELECTRIC CO LTD	LM-3	for model HL-200K, 5-15P, 125V, 15A. E310740	UL
			ZHEJIANG JINTING NUCLEAR CABLE CO LTD	JT2-3I	For model HL-400KC, 6-20P, 250V, 20A. E306012	UL
16	3	Internal cord	ZHEJIANG JINTING NUCLEAR CABLE CO LTD	SJT	600V, 105°C, No. 16AWG x 2 E308842	UL
			NINGBO LINSHENG ELECTRIC CO LTD	SJT	600V, 105°C, No. 16AWG x 2 E218475	UL
1	4	Overall Enclosure	HEALTHLAND SAUNA EQUIPMENT CO LTD	Hemlock	Flame spread rating 50. Incorporated several wall panels, a bottom panel and a ceiling panel. The wall panels are embedded in the grooves of the bottom panel and ceiling panel. Intertek Test Report 180226004SHF-BP-1.	NR
1	5	Temper Glass	XUZHOU FANGDI GLASS	temper glass	4mm thickness	NR
6	6	Ventilation	HEALTHLAND SAUNA EQUIPMENT CO LTD	Various	the inlet ventilation is located as close to the floor level as possible. The outlet ventilation is located on the ceiling. The areal of ventilation opening is larger than 60 square centimeters. detail to see Illustration Ventilation	NR
4	7	LED	XUZHOU XINGETE ELECTRIC TECHNOLOGY CO., LTD	YCG02	12V d.c., 1.2W	NR

4.0 Critical Components						
Photo #	Item no. <sup>1</sup>	Name	Manufacturer/ trademark <sup>2</sup>	Type / model <sup>2</sup>	Technical data and securement means	Mark(s) of conformity <sup>3</sup>
12	8	Coupler	SHAOXING LIMA ELECTRIC CO LTD	LM-3ZP	250V, 10A. Connected to heater E310740	UL
12	9	Female connector	SHAOXING LIMA ELECTRIC CO LTD	LM-3ZR	250V, 10A, connected to control box E310740	UL
3	10	Control Panel	HEALTHLAND SAUNA EQUIPMENT CO LTD	Various	Incorporate a power control (ON/OFF), an internal light control (independent of power switch control), a time control (max. 60 min) and a temperature control (max. 60 degree) provided both indoor & outdoor	NR
1	11	Label	KK ENTERPRISE CO LTD	KK-TACK-TLT50	-20~125°C MH13600	UL
10	12	Metal Conduit	BLISS YIH ENTERPRISE CO LTD	3/8"d	-15°C-105°C, 10mm or 14.4mm all wires to heater are enclosed by metal conduit E118165	UL
22	13	Temperature sensor	Dongguan Xingxiang Electronics Technology Co., Ltd.	NTC	Rated 5Vdc, -20-105°C.	NR
19	14	Insulated Tape	3M COMPANY ELECTRICAL MARKETS DIV (EMD)	1069	180°C, Flame retardant, White, Thickness: 0.18mm E17385	UL
20	15	Terminal Block	KOREA AUTO CONTROLS CO LTD	KTB1-020	300V, 20A, 14-16AWG, 4P, T115. Located in the terminal box for heater connection. E249317	NR
23	16	Heater	Changzhou Zaodao Electric Co., Ltd.	HL1	120V~, 60Hz 120W, 20×80CM. See Illustration 9, table 2 in Sec. 7.0 for detailed number used and position of heater.	See 5.0
1	17	Heater (Not shown)	Changzhou Zaodao Electric Co., Ltd.	HL2	120V~, 60Hz 180W 30×80CM. See Illustration 9, table 2 in Sec. 7.0 for detailed number used and position of heater.	See 5.0
1	18	Heater (Not shown)	Changzhou Zaodao Electric Co., Ltd.	HL3	120V~, 60Hz 300W, 40×100CM. See Illustration 9, table 2 in Sec. 7.0 for detailed number used and position of heater.	See 5.0
1	19	Heater (Not shown)	Changzhou Zaodao Electric Co., Ltd.	HL4	120V~, 60Hz 330W, 50×90CM. See Illustration 9, table 2 in Sec. 7.0 for detailed number used and position of heater.	See 5.0

4.0 Critical Components						
Photo #	Item no. <sup>1</sup>	Name	Manufacturer/ trademark <sup>2</sup>	Type / model <sup>2</sup>	Technical data and securement means	Mark(s) of conformity <sup>3</sup>
19	20	Thermostat	CHWEN-DER THERMOSTAT & CO LTD	CD79F085	250V, 60Hz, 10A, 85°C, 100K cycles. E75072	UL
19	21	Thermal Link	THERM-O-DISC INC, SUB OF EMERSON ELECTRIC CO	G4A01	120V, 10A, 110°C E40667	UL
19	22	Heating shrinkable tube	SHENZHEN WOER HEAT-SHRINKABLE MATERIAL CO LTD	RSFR-x	600V, 125°C, VW-1 E203950	UL
19	23	Leads	JIANGYIN ZHIJUN APPLIANCE ELECTRIC CABLE & WIRE CO LTD	3122	300V, 200°C, 16AWG, covered by heating shrinkable tube E301946	UL
12	24	Outlet Bushings and Fittings	KAI SUH SUH ENTERPRISE CO LTD	EG-11 EG-13.5	Cable range 3~6.5 mm <sup>2</sup> E186042	UL
13	25	PCB	SHENZHEN JETFGO CIRCUITS CO LTD	JFG01	94V-0, 105°C. Min. 1.5 mm thickness. There is an industrial laminate between the PCBs and metal enclosure, which material is as same as PCB E218213	UL
13	26	Internal wire in control box	ANHUI XINKE NEW MATERIALS STOCK CO LTD CABLE & WIRES BRANCH CO	1015	18AWG, 600V, 105°C E220455	UL
13	27	Circuit Breaker	QICHENG ELECTRICAL EQUIPMENT CO LTD	CCB260	120Vac, for model HL-200K: 15A; for model HL-400KC: 20A E313354	UL
10	28	Control Box	Xuzhou Yate Equipment Co., Ltd	Painted steel	Painted steel, 280 x 240 x 50 mm, thickness: 1.2mm	NR
14	29	Relay for Heater	XINLING ELECTRICAL CO LTD CHINA	HHC67E-1H-12VDC	Input: 12Vdc, output: 240VAC, 30A, T85, 100K, E235027	UL
14	30	Relay for LED	SANYOU CORPORATION LIMITED	SRD-S-112DM	250Vac, 10A, T105, 100K E190598	UL
13	31	Power Switching supply	CHANGZHOU CHUANGLIAN POWER SUPPLY TECHNOLOGY CORPORATION	A-75FAM-12	Input: 100-240V, 50/60Hz, Output: 12VDC, 6A, T50 E255042	UL
				A-150FAO-12	Input: 100-240VAC, 50/60Hz, Output: 12VDC, 12.5A, T50 E255042	UL

4.0 Critical Components						
Photo #	Item no. <sup>1</sup>	Name	Manufacturer/ trademark <sup>2</sup>	Type / model <sup>2</sup>	Technical data and securement means	Mark(s) of conformity <sup>3</sup>
14	32	Cable tie	KAI SUH SUH ENTERPRISE CO LTD	TCV-155	Max. Bundle 40mm Min Tensile strength 18 kg E97527	UL
20	33	Silicone varnished fiberglass sleeving	JIANGYIN HUAQIANG RUBBERS & PLASTICS CO LTD	SRG	VW-1, White E231589	UL
24	34	Terminal Block	CIXI WANJIE ELECTRON CO LTD	WJ45C	300V, 20A, 12-22AWG, 4P, T105. Located in the Control Box for heater connection. E251331	UL
24	35	Terminal Block	CIXI WANJIE ELECTRON CO LTD	WJ78C	600V, 30A, 10-18AWG, 2P, T105. Located in the Control Box for heater connection. E251331	UL
24	36	Terminal Block	CIXI WANJIE ELECTRON CO LTD	WJ25S	300V, 15A, 14-22AWG, 2P, T105. Located in the Control Box for LED connection. E251331	UL
20	37	Terminal Box	Various	Painted steel	Thickness: 1.2mm, for heater connection	NR
24	38	Varistor	BESTBRIGHT ELECTRONICS CO LTD	14D471K	300VAC, T105, Vn470V E315524	UL

NOTES:

- 1) Not all item numbers are indicated (called out) in the photos, as their location is obvious.
- 2) "Various" means any type, from any manufacturer that complies with the "Technical data and securement means" and meets the "Mark(s) of conformity" can be used.
- 3) Indicates specific marks to be verified, which assures the agreed level of surveillance for the component. "NR" - indicates Unlisted and only visual examination is necessary. "See 5.0" indicates Unlisted components or assemblies to be evaluated periodically refer to section 5.0 for details.

5.0 Critical Unlisted CEC Components					
HEATER ELEMENT					
Photo #	Item no.	Name	Manufacturer/Trademark	Type / model	
23	16	Heater	Changzhou Zao dao Electric Co., Ltd.	HL1	
Electrical Rating: 120V~, 60Hz, 120W			Insulation class None		
Component Standard used: UL875, CSA164, UL499					
MATERIALS LIST (refer to illustration - heater for assembly drawing)					
Component	Manufacturer	Type/model	Dimensions/thickness/assembly information		
Carbon Fiber paper	JAPAN JUJO	DDA-SH-1040	Thickness: 0.02mm		
Industrial laminate	KINGBOARD LAMINATES (MACAO COMMERCIAL OFFSHORE) LTD	KB-6160A	Rated 94V-0, 130°C . 0.2 mm thickness.5 layers Provided with two copper strips on two ends acting as electrodes.		
Insulated tape	Ref. to Item 14	Ref. to Item 14	Ref. to Item 14		
thermostat	Ref. to Item 20	Ref. to Item 20	Ref. to Item 20		
thermal link	Ref. to Item 21	Ref. to Item 21	Ref. to Item 21		
Leads	Ref. to Item 23	Ref. to Item 23	Ref. to Item 23		
ELEMENT RESISTANCE					
Element Designation	Overall assembled dimensions		Volts	Watts	DC resistance (Ω) +/- 5%:
HL1	200 X 800 X 1mm		120V	120W	120 (20°C)
VERIFICATION PROCESS					
Frequency: Annual		Test Site: CEC		Number of samples to test: 1	
Test Name		Test Parameters			
Winding resistance		See resistance per element above.			
Dielectric Strength	Apply voltage Between		Test Voltage	Test Time	
	Live parts and housing		4000V	60 s	
HEATER ELEMENT					
Photo #	Item no.	Name	Manufacturer/Trademark	Type / model	
1	17	Heater (Not shown)	Changzhou Zao dao Electric Co., Ltd.	HL2	
Electrical Rating: 120V~, 60Hz, 180W			Insulation class None		
Component Standard used: UL875, CSA164, UL499					
MATERIALS LIST (refer to illustration - Heater for assembly drawing)					
Component	Manufacturer	Type/model	Dimensions/thickness/assembly information		
Carbon Fiber paper	JAPAN JUJO	DDA-SH-1040	Thickness: 0.02mm		
Industrial laminate	KINGBOARD LAMINATES (MACAO COMMERCIAL OFFSHORE) LTD	KB-6160A	Rated 94V-0, 130°C . 0.2 mm thickness.5 layers Provided with two copper strips on two ends acting as electrodes.		
Insulated tape	Ref. to Item 14	Ref. to Item 14	Ref. to Item 14		
thermostat	Ref. to Item 20	Ref. to Item 20	Ref. to Item 20		
thermal link	Ref. to Item 21	Ref. to Item 21	Ref. to Item 21		
Leads	Ref. to Item 23	Ref. to Item 23	Ref. to Item 23		
ELEMENT RESISTANCE					
Element Designation	Overall assembled dimensions		Volts	Watts	DC resistance (Ω) +/- 5%:
HL2	300 X 800 X 1mm		120V	180W	80 (20°C)

5.0 Critical Unlisted CEC Components			
VERIFICATION PROCESS			
Frequency: <b>Annual</b>	Test Site: <b>CEC</b>	Number of samples to test: <b>1</b>	
Test Name	Test Parameters		
Winding resistance	See resistance per element above.		
Dielectric Strength	Apply voltage Between	Test Voltage	Test Time
	Live parts and housing	4000V	60 s

HEATER ELEMENT				
Photo #	Item no.	Name	Manufacturer/Trademark	Type / model
1	18	Heater (Not shown)	Changzhou Zaodao Electric Co., Ltd.	HL3
Electrical Rating: 120V, 60Hz, 300W				Insulation class None
Component Standard used: UL875, CSA164, UL499				

MATERIALS LIST (refer to illustration - Heater for assembly drawing)			
Component	Manufacturer	Type/model	Dimensions/thickness/assembly information
Carbon Fiber paper	JAPAN JUJO	DDA-SH-1040	Thickness: 0.02mm
Industrial laminate	KINGBOARD LAMINATES (MACAO COMMERCIAL OFFSHORE) LTD	KB-6160A	Rated 94V-0, 130°C . 0.2 mm thickness.5 layers Provided with two copper strips on two ends acting as electrodes.
Insulated tape	Ref. to Item 14	Ref. to Item 14	Ref. to Item 14
thermostat	Ref. to Item 20	Ref. to Item 20	Ref. to Item 20
thermal link	Ref. to Item 21	Ref. to Item 21	Ref. to Item 21
Leads	Ref. to Item 23	Ref. to Item 23	Ref. to Item 23

ELEMENT RESISTANCE				
Element Designation	Overall assembled dimensions	Volts	Watts	DC resistance (Ω) +/- 5%:
HL3	400 X 1000 X 1mm	120V	300W	48 (20°C)

VERIFICATION PROCESS			
Frequency: <b>Annual</b>	Test Site: <b>CEC</b>	Number of samples to test: <b>1</b>	
Test Name	Test Parameters		
Winding resistance	See resistance per element above.		
Dielectric Strength	Apply voltage Between	Test Voltage	Test Time
	Live parts and housing	4000V	60 s

HEATER ELEMENT				
Photo #	Item no.	Name	Manufacturer/Trademark	Type / model
1	19	Heater (Not shown)	Changzhou Zaodao Electric Co., Ltd.	HL4
Electrical Rating: 120V~, 60Hz, 330W				Insulation class
Component Standard used: UL875, CSA164, UL499				

MATERIALS LIST (refer to illustration _ for assembly drawing)			
Component	Manufacturer	Type/model	Dimensions/thickness/assembly information
Carbon Fiber paper	JAPAN JUJO	DDA-SH-1040	Thickness: 0.02mm
Industrial laminate	KINGBOARD LAMINATES (MACAO COMMERCIAL OFFSHORE) LTD	KB-6160A	Rated 94V-0, 130°C . 0.2 mm thickness.5 layers Provided with two copper strips on two ends acting as electrodes.
Insulated tape	Ref. to Item 14	Ref. to Item 14	Ref. to Item 14

<b>5.0 Critical Unlisted CEC Components</b>				
Thermostat	Ref. to Item 20	Ref. to Item 20	Ref. to Item 20	
thermal link	Ref. to Item 21	Ref. to Item 21	Ref. to Item 21	
Leads	Ref. to Item 23	Ref. to Item 23	Ref. to Item 23	
<b>ELEMENT RESISTANCE</b>				
Element Designation	Overall assembled dimensions	Volts	Watts	DC resistance (Ω) +/- 5%:
HL4	500 X 900 X 1mm	120V	330W	43.6 (20°C)
<b>VERIFICATION PROCESS</b>				
Frequency: <b>Annual</b>		Test Site: <b>CEC</b>		Number of samples to test: <b>1</b>
Test Name	Test Parameters			
Winding resistance	See resistance per element above.			
Dielectric Strength	Apply voltage Between	Test Voltage	Test Time	
	Live parts and housing	4000V	60s	

## 6.0 Critical Features

Recognized Component - A component part, which has been previously evaluated by an accredited certification body with restrictions and must be evaluated as part of the basic product considering the restrictions as specified by the Conditions of Acceptability.

Listed Component - A component part, which has been previously Listed or Certified by an accredited Certification Organization with no restrictions and is used in the intended application within its ratings.

Unlisted Component - A part that has not been previously evaluated to the appropriate designated component standard. It may also be a Listed or Recognized component that is being used outside of its evaluated Listing or component recognition.

Critical Features/Components - An essential part, material, subassembly, system, software, or accessory of a product that has a direct bearing on the product's conformance to applicable requirements of the product standard.

Construction Details - For specific construction details, reference should be made to the photographs and descriptions. All dimensions are approximate unless specified as exact or within a tolerance. In addition to the specific construction details described in this Report, the following general requirements also apply.

1. Spacing - In primary circuits, a minimum of 1.6mm spacing is maintained through air and over surfaces of insulating material between current-carrying parts of opposite polarity and between current-carrying parts and dead-metal parts. A minimum of 6.4mm spacing is maintained through air and over surfaces of insulating material between live parts and a conductive enclosure.
2. Mechanical Assembly - Components such as switches, fuseholders, connectors, wiring terminals and display lamps are mounted and prevented from shifting or rotating by the use of lockwashers, starwashers, or other mounting format that prevents turning of the component.
3. Corrosion Protection - All ferrous metal parts are protected against corrosion by painting, plating or the equivalent.
4. Accessibility of Live Parts - All uninsulated live parts in primary circuitry are housed within a enclosure constructed with no openings other than those specifically described in Sections 4 and 5.
5. Grounding - All exposed dead-metal parts and all dead-metal parts within the enclosure that are exposed to contact during any servicing operation and that are likely to become energized are reliably connected to the grounding terminal lead of the power supply cord or the equipment grounding terminal.
6. Internal Wiring - Internal wiring is reliably routed away from sharp or moving parts. Internal wiring leads terminating in soldered connections are made mechanically secure prior to soldering. Recognized separable (quick disconnect) connectors of the positive detent type, closed loop connectors, or other types specifically described in the text of this report are also acceptable as internal wiring terminals. At points where internal wiring passes through metal walls or partitions, the wiring insulation is protected against abrasion or damage by plastic bushings or grommets. All wiring is min. 16 AWG, with a min. rating of 300V, 200°C.
7. Schematics - Refer to Illustration 4.1, 4.2 for schematics requiring verification during Field Representative Inspection Audits.
8. Markings - Refer to item 11 of section 4 and illustration 1.1, 1.2 of section 7 for details.
10. Cautionary Markings - Refer to illustration 3.1, 3.2 of section 7 for details.
11. Installation, Operating and Safety Instructions - Refer to illustration 8.1 to illustration 8.22 of section 7 for details.

**7.0 Illustrations**

**Illustration 1.1 - Name Plate**



**Illustration 1.2 - Multiple Listing Name Plate (Representative)**



**7.0 Illustrations**

**Illustration 2 - Heater nameplate**

Changzhou Zaodao Electric Co., Ltd.

Model:HL1

Dimension:200 mm\*800mm

Rated Voltage: AC 120V

Rated Frequency:60Hz

Input Power:120 W

Changzhou Zaodao Electric Co., Ltd.

Model:HL3

Dimension:400 mm\*1000mm

Rated Voltage: AC 120V

Rated Frequency:60Hz

Input Power: 300W

Changzhou Zaodao Electric Co., Ltd.

Model:HL2

Dimension:300 mm\*800mm

Rated Voltage: AC120 V

Rated Frequency:60Hz

Input Power: 180W

Changzhou Zaodao Electric Co., Ltd.

Model:HL4

Dimension: 500mm\*900mm

Rated Voltage: AC 120V

Rated Frequency:60Hz

Input Power:330 W

**7.0 Illustrations**

**Illustration 3.1 - Warning Label**

 **CAUTION**

Excess Exposure Can Be Harmful For Health. Persons With Poor Health Should Consult Their Physicians Before Using Sauna  
Une exposition Excessive Peut Être Nuisible À La Santé . Les Personnes Qui Ne Jouissent Pas D'une Bonne Santé Devraient Consulter Leur Médecin Avant D'utiliser Ce Sauna.

 **WARNING  
DANGER GÉNÉRAL**

**REDUCE THE RISK OF ELECTROCUTION**  
Disconnect All Supply Connections Before Servicing  
**RISQUES D'ÉLECTROCUTION**  
Débrancher toutes les connexions avant d'effectuer le service et/ou la réparation.

 **WARNING  
DANGER GÉNÉRAL**

**REDUCE THE RISK OF FIRE**  
Do Not Install Closer Than 12.7mm (0.5 inches) To A (Vertical/Horizontal) Surface  
**RÉDUIRE LES RISQUES DE FEU**  
Ne jamais placer des matériaux combustibles près et/ou sur l'élément chauffant.

 **WARNING  
DANGER GÉNÉRAL**

**REDUCE THE RISK OF ELECTROCUTION AND BURNS**  
Do Not Operate Unless Guard Is In Place.  
Interdiction d'apporter de l'eau et/ou une serviette mouillée

 **CAUTION**

CAUTION: A NONMETALLIC GUARDRAIL SHALL BE INSTALLED NOT CLOSER THAN \_\_\_\_\_mm FROM THE SAUNA HEATER. SEE INSTALLATION INSTRUCTIONS  
ATTENTION: UNE BARRE DE PROTECTION NON MÉTALLIQUE DOIT ÊTRE INSTALLÉE À AU MOINS \_\_\_\_\_mm DU CHAUFFE-SAUNA. CONSULTER LES INSTRUCTIONS D'INSTALLATION.

 **WARNING  
DANGER GÉNÉRAL**

**REDUCE THE RISK OF FIRE**  
Do Not Place Combustible Material On Heater At Any Time.  
**RÉDUIRE LES RISQUES DE FEU**

 **CAUTION**

CAUTION: DO NOT INSULATE THE CEILING, WALLS OR FLOOR MORE THAN R-12  
ATTENTION: NE PAS UTILISER UN ISOLANT D'UNE VALEUR SUPÉRIEURE À R-12 POUR LE PLAFOND, LES MURS OU LE PLANCHER

 **CAUTION**

CAUTION: DO NOT INSTALL SHOWER HEADS OR WATER SPRAY DEVICES ABOVE THE SAUNA HEATER;  
ATTENTION: NE PAS INSTALLER DE POMMES DE DOUCHE NI D'AUTRES DISPOSITIFS D'ARRROSAGE AU-DESSUS DU CHAUFFE-SAUNA.

**USE Copper Wire Only**

 **CAUTION**

CAUTION: THE MANUAL RESET LIMIT SHALL BE WIRED IN THE CIRCUIT.  
ATTENTION: INTERCALER LE LIMITEUR À RÉARMEMENT MANUEL DANS LE CIRCUIT

**IT IS UNLAWFUL TO INSTALL THIS UNIT WITHOUT FIRST OBTAINING A PERMIT FROM THE LOCAL ELECTRICAL INSPECTION AUTHORITY;**  
**IL EST TLLÉ GAL D'INSTALLER CET APPAREIL SANS PERMIS PRÉ ALABLE DES AUTORITES LOCALES D'INSPECTION EN É LECTRICITÉ**

**For Household Use Only**

7.0 Illustrations

Illustration 3.2 - Warning Label

	<b>WARNING DANGER GÉNÉRAL</b>
<b>REDUCE THE RISK OF OVERHEATING</b>	
<ol style="list-style-type: none"><li>1. Exit immediately if uncomfortable, dizzy, or sleepy. Staying too long in a heated area is capable of causing overheating.</li><li>2. Supervise children at all times.</li><li>3. Check with a doctor before use if pregnant, in poor health, or under medical care.</li><li>4. Breathing heated air in conjunction with consumption of alcohol, or drugs, or medication is capable of causing unconsciousness.</li></ol>	
<b>RÉDUIRE LES RISQUES DE COUP DE CHALEUR</b>	
<ol style="list-style-type: none"><li>1. Si vous ressentez un ou plusieurs de ces symptômes : étourdissements, fatigue ou inconfort, veuillez sortir immédiatement. Rester dans un environnement trop chaud pour une longue durée peut causer des coups de chaleur.</li><li>2. Superviser les enfants en tout temps.</li><li>3. Vérifier auprès de votre médecin avant d'utiliser si vous êtes enceinte, en mauvaise santé ou sous médicaments.</li><li>4. La combinaison de la consommation d'alcool et d'un environnement chaud pourrait causer l'évanouissement.</li></ol>	

	<b>CAUTION</b>
AVOID A FIRE DO NOT PLACE COMBUSTIBLE MATERIAL ON SAUNA HEATER LE CHAUFFE- SAUNA.	

	<b>ATTENTION</b>
ÉVITEZ LES INCENDIES, NE PLACEZ AUCUNE MATIÈRE COMBUSTIBLE SUR	

**7.0 Illustrations**

**Illustration 4.1 - Electrical Schematic for HL-200K (Representative)**

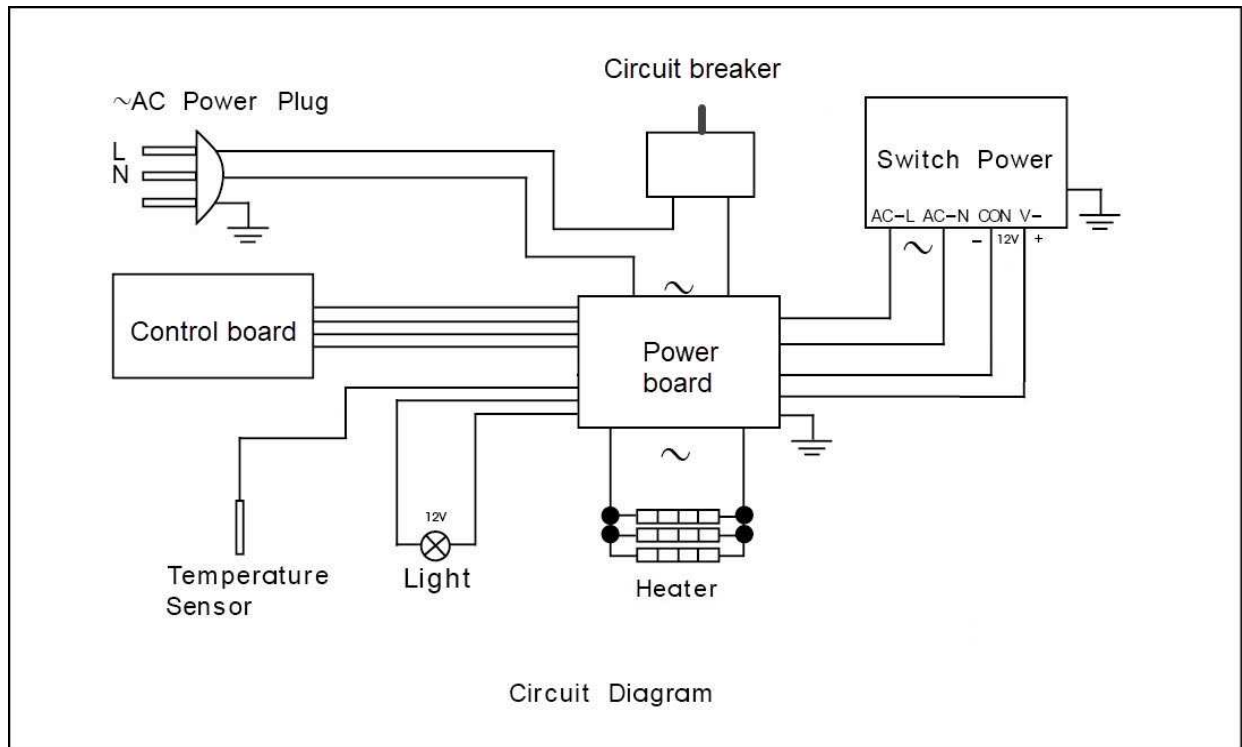



7.0 Illustrations

Illustration 5.1 - Heater

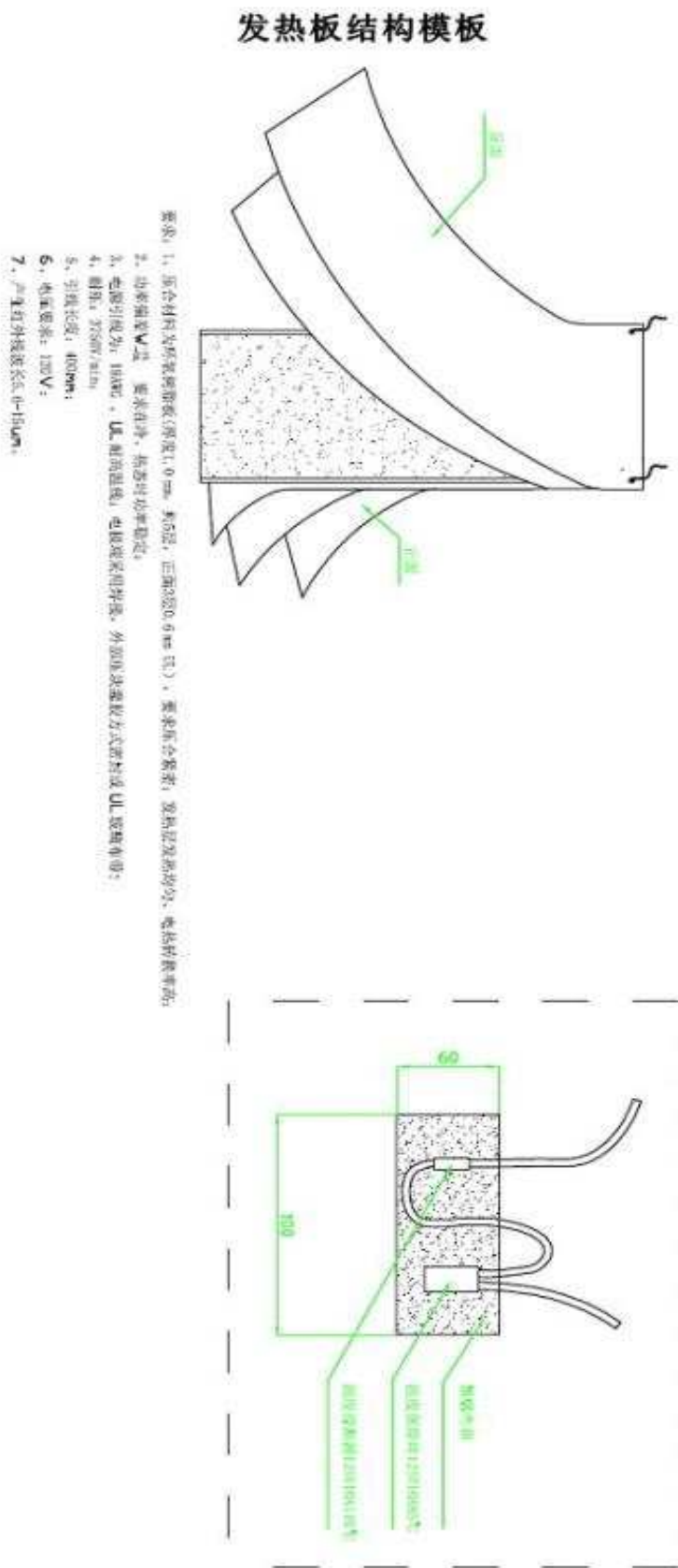

**7.0 Illustrations**

**Illustration 5.2 - Heaters**

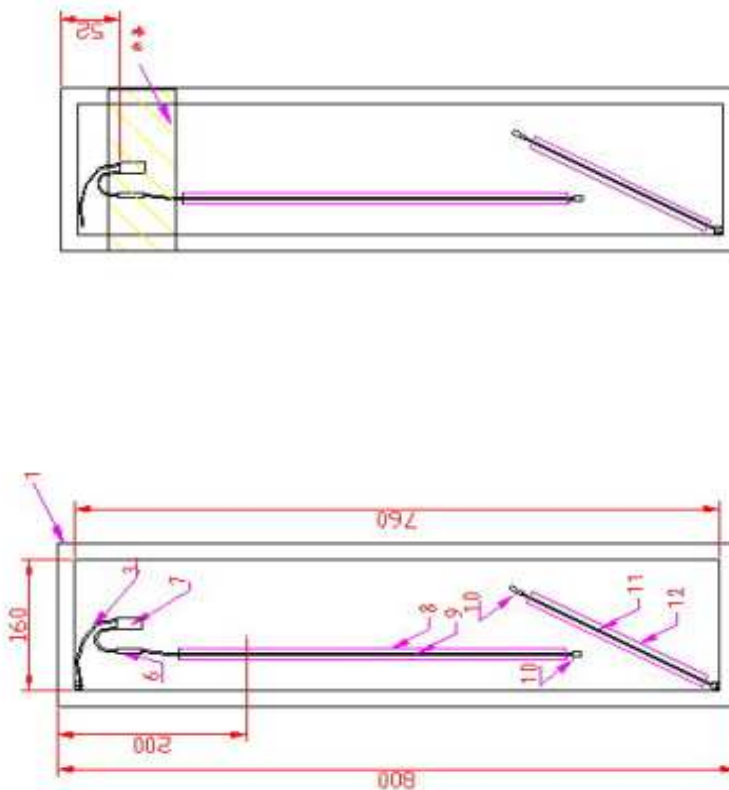
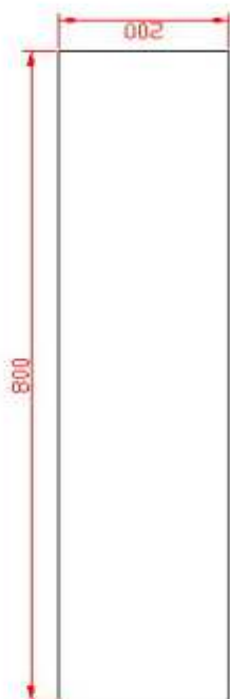

序号	品名	规格/型号/描述	材质	数量	备注
1	LED-018MC001	100*800mm 110V/1.200W/1.20A	E111593	1	
2					
3	不锈钢加热器	2000mm 1.0mm <sup>2</sup>	E111450	1	
4					
5					
6	不锈钢加热器	440.01 110V	E10667	1	
7	不锈钢加热器	2079E 45度	E11165	1	
8	不锈钢加热器	340mm	E11165	1	外加两个金属护口
9	不锈钢加热器	350mm 1.0mm <sup>2</sup>	E111450	1	
10	不锈钢加热器	211.2mm <sup>2</sup>	E107931	1	
11	不锈钢加热器	25.0mm 1.0mm <sup>2</sup>	E111450	1	
12	不锈钢加热器	340mm	E11165	1	外加两个金属护口

设计					
审核					
批准					
日期					

200\*800mm 加热器

**7.0 Illustrations**

**Illustration 5.3 - Heater**

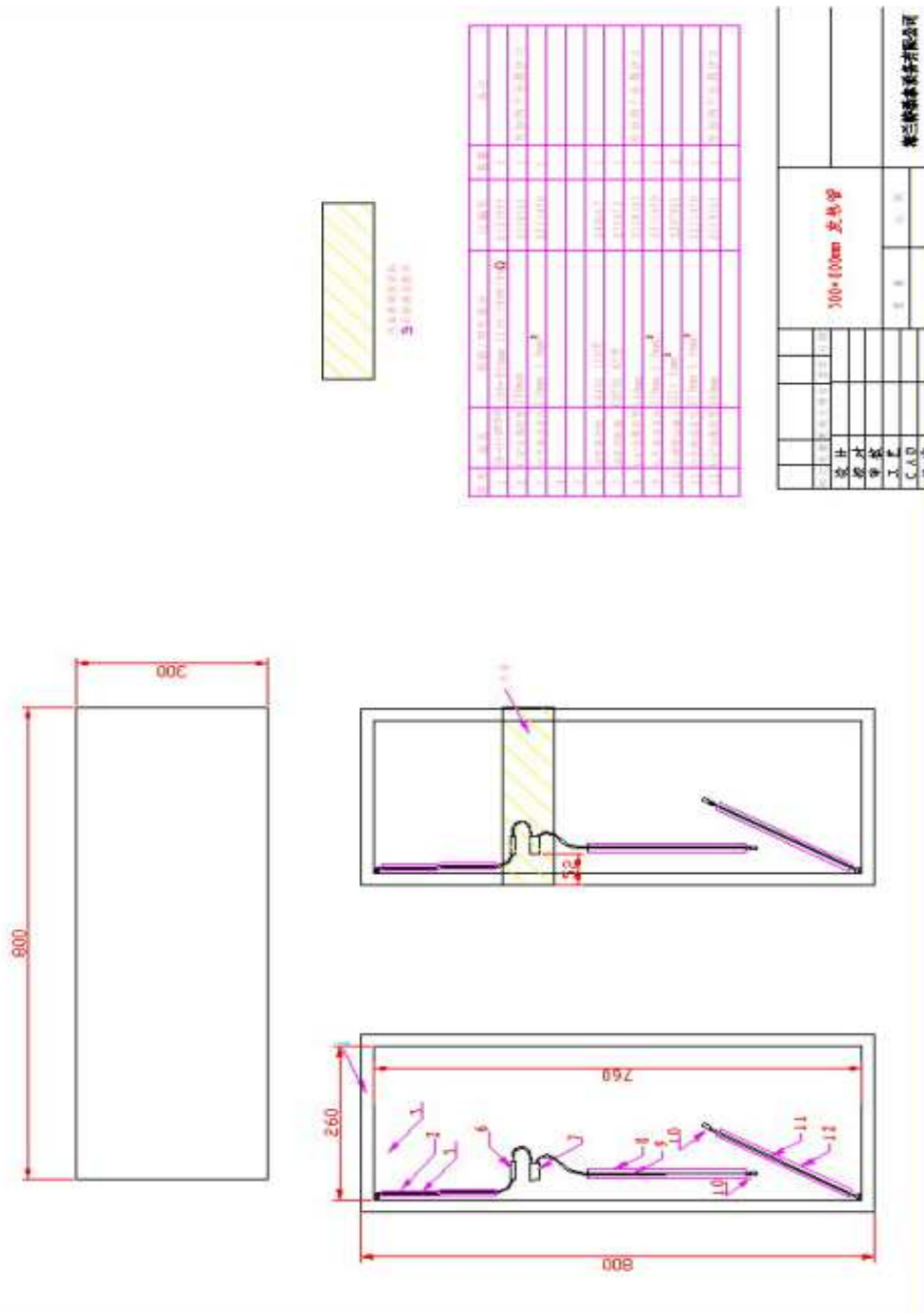

**7.0 Illustrations**

**Illustration 5.4 - Heater**

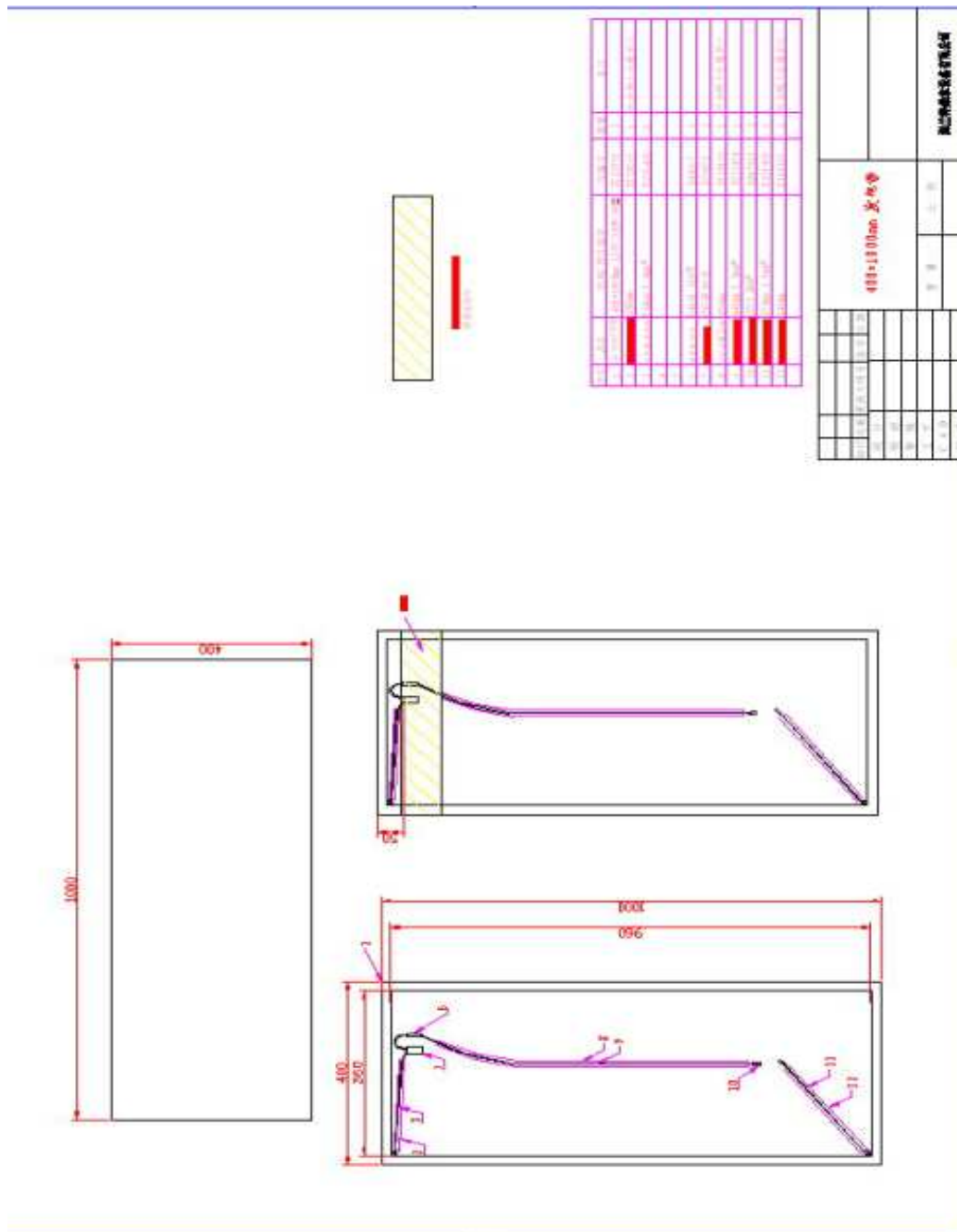

**7.0 Illustrations**

**Illustration 5.5 - Heaters**

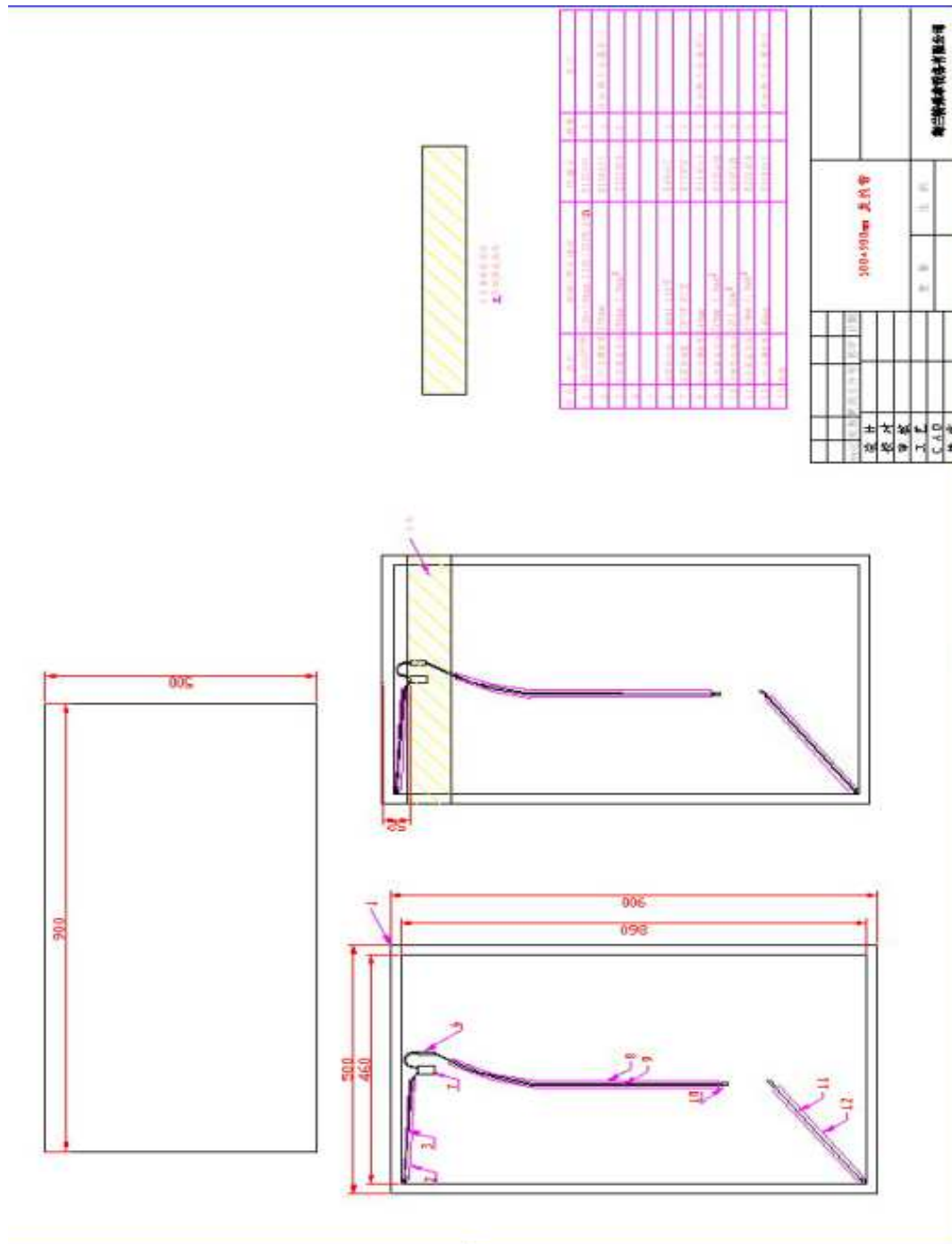

7.0 Illustrations

Illustration 6 - Ventilation

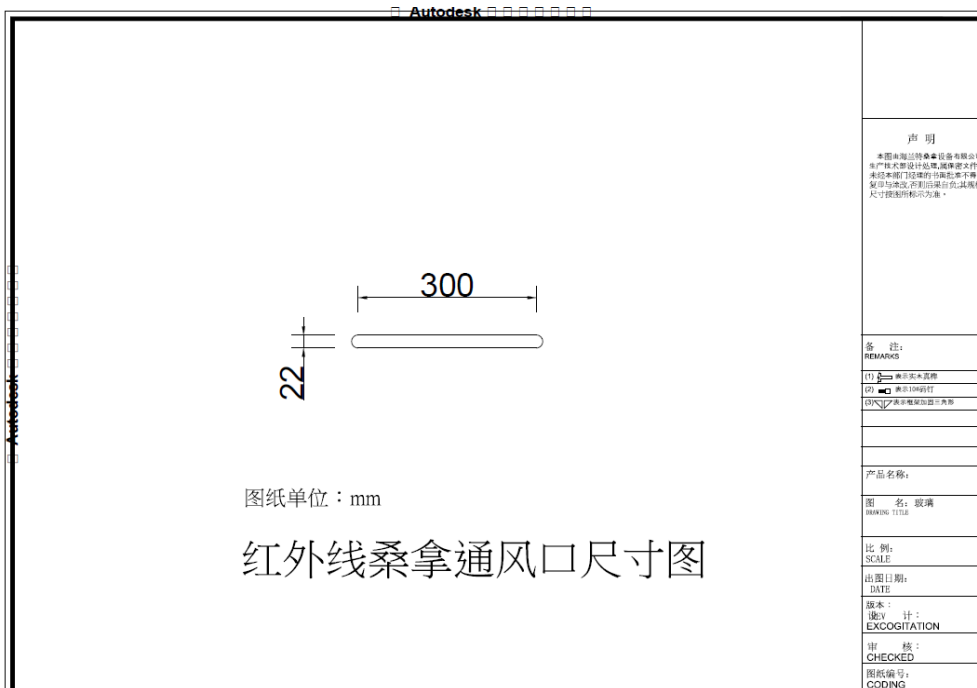

7.0 Illustrations

Illustration 7 - Wooden Guard

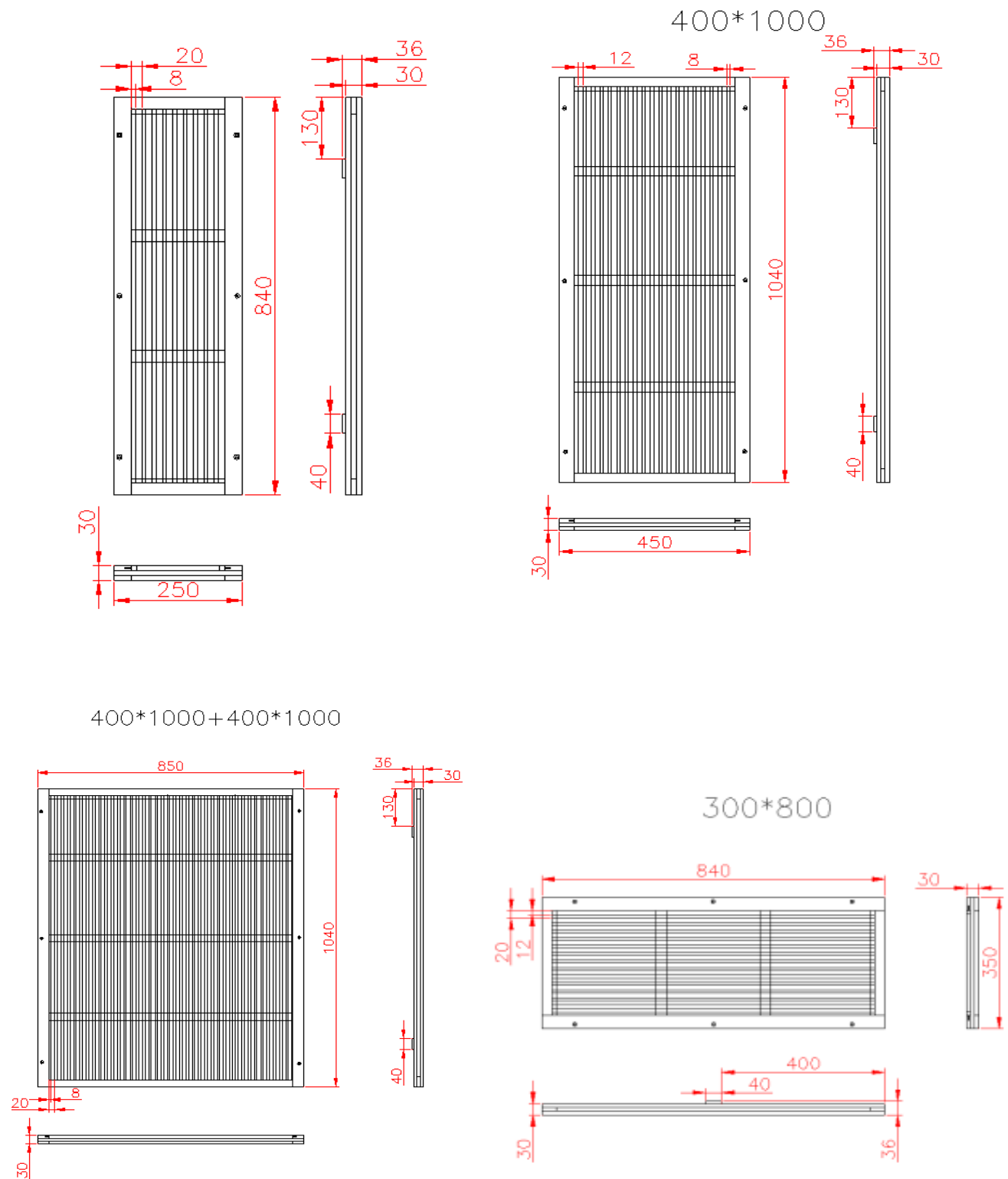

**7.0 Illustrations**

**Illustration 8.1 - Manual (HL-200K)**

# SAUNA MANUAL



CONFORMS TO  
UL STD. 875  
CERTIFIED TO  
CSA STD. C22.2 NO.164

**The New Generation Sauna In The World!**

HEALTHLAND SAUNA EQUIPMENT CO LTD

Made In China

**7.0 Illustrations**

**Illustration 8.2 - Manual (HL-200K)**

**WARNINGS**

**1. THE FOLLOWING WARNING LABEL IS ON THE FRONT OF SAUNAS**

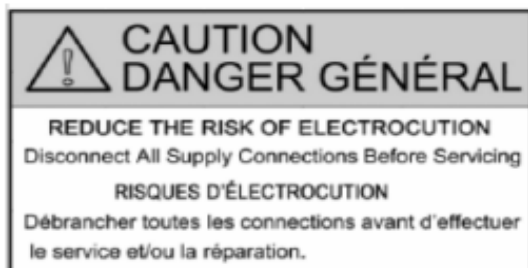

**2. THE FOLLOWING WARNING LABEL IS ON THE SIDE OF THE HEATER**

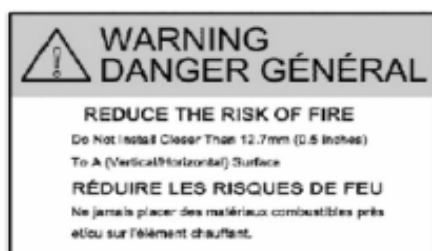
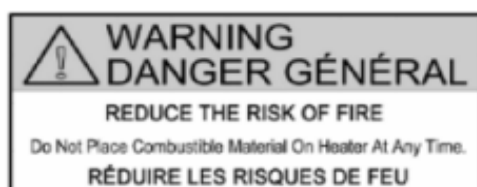

7.0 Illustrations

Illustration 8.3 - Manual (HL-200K)

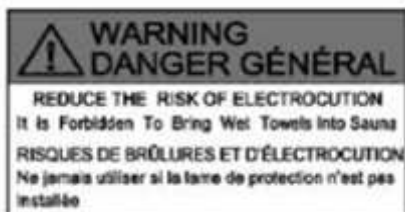

THE FOLLOWING WARNING LABEL IS ON THE DOOR AND THE WALL OF THE ROOM.



THE FOLLOWING WARNING LABEL IS ON THE DOOR OR THE WALL BESIDE THE DOOR.



## 7.0 Illustrations

### Illustration 8.4 - Manual (HL-200K)

## IMPORTANT SAFETY GUIDES

### READ AND FOLLOW ALL INSTRUCTIONS

A) Reference to the warning marking provided with the heater, indicating the importance of attaching the marking. There are the relevant explanation for all kinds of warning notice, also there is the limite for the location of warning notice as below:

- 1) the hyperthermia warning marking should be located on the outside of the door at eye level.
- 2)The fire warning marking should be located on the interior wall above the heater at eye level.

B) A receptacle shall not be installed inside the heated room.

C) The door of the heated room do not include any locking or latching system, malfunction of which could cause entrapment inside the heated room.

D) Keep the intended ventilation open when use the dry-bath bathing room.

E) **CAUTION: Hyperthermia occurs when the internal temperature of the body reaches a level several degrees above the normal body temperature of 98.6°F(37°C). The symptoms of hyperthermia include an increase in the internal temperature of the body, dizziness, lethargy, drowsiness, and fainting. The effects of hyperthermia include:**

- a) Failure to perceive heat;
- b) Failure to recognize the need to exit the room;
- c) Unawareness of impending hazard;
- d) Fetal damage in pregnant women;
- e) Physical inability to exit the room; and
- f) Unconsciousness.

**WARNING – The use of alcohol, drugs, or medication is capable of greatly increasing the risk of fatal hyperthermia.**

G) **WARNING: REDUCE THE RISK OF ELECTROCUTION AND BURNS, DO NOT OPERATE UNLESS GUARD IS IN PLACE.**

H) **CAUTION: EXCESSIVE EXPOSURE CAN BE HARMFUL TO HEALTH. PERSONS WITH POOR HEALTH SHOULD CONSULT THEIR PHYSICIANS BEFORE USING SAUNA.**

I) **CAUTION: REDUCE THE RICK OF FIRE, DO NOT PLACE COMBUSTIBLE MATERIAL ON HEATER AT ANY TIME.**

J) **WARNING: REDUCE THE RISK OF OVERHEATING:**

a)**EXIT IMMEDIATELY IF UNCOMFORTABLE, DIZZY, OR SLEEPY, STAYING TOO LONG IN A HEATED AREA IS CAPABLE OF CAUSING OVERHEATING.**

b)**SUPERVISE CHILDREN AT ALL TIMES.**

c) **CHECK WITH A DOCTOR BEFORE USE IF PREGNANT, IN POOR HEALTH, OR UNDER MEDICAL CARE.**

d) **BREATHING HEATED AIR IN CONJUNCTION WITH CONSUMPTION OF ALCOHOL, DRUGS, OR MEDICATION IS CAPABLE OF CAUSING UNCONSCIOUSNESS.**

K) **WARNING: REDUCE THE RISK OF ELECTROCUTION, DISCONNECT THE SUPPLY CONNECT BEFORE SERVICING.**

## SAVE THESE INSTRUCTIONS

## 7.0 Illustrations

### Illustration 8.5 - Manual (HL-200K)

#### **Dear Customer,**

Congratulations on your purchase of the sauna, the new generation Sauna in the world. We are confident that you will enjoy the many benefits of using the sauna for years to come.

Carefully and thoroughly read this manual in its entirety before using the sauna for the first time. We recommend keeping this manual for regular review and future reference.

I attribute this growth and success entirely to our customer satisfaction, the recognized health benefits, and the quality of our workmanship. we use only the finest materials coupled with state-of-the-art construction and the highest safety standard in the industry.

You will be surprised at the noticeable effects on pain relief, weight control, skin stimulation, and stress reduction due to an increased blood circulation when using the sauna.

Whatever your needs, we invite you to experience the difference with the sauna: A difference in health benefit, a difference in quality, and a difference in attitude of our team service and support.

The whole team is looking forward to serving your needs.

#### **TABLE OF CONTENTS**

Conditions of use Page	(4)
Packaging and Individual Panel Information Page	(4-6)
Installation Information Page	(6)
Assembly Instructions Page	(6-13)
Digital Controller Operating Instructions Page	(13-14)
Enjoying Your Sauna Page	(14-15)
Tips for Use Page	(15)
Warnings Safety Instructions Page	(16)
Limited Warranty Page	(17)
Frequently Asked Questions Page	(17-20)
Maintenance Page	(20)

## 7.0 Illustrations

### Illustration 8.6 - Manual (HL-200K)

#### Conditions of use

1. Temperature from  $+15 \sim +40^{\circ}\text{C}$  ( $+41^{\circ}\text{F} \sim +104^{\circ}\text{F}$ )
2. Relative humidity  $\leq 85\%$
3. Depression: 700~1060 hpa
4. Main supply: AC  110V  220V  240V  
Frequency:  60Hz $\pm 1$   50Hz $\pm 1$
5. For household only

HL-200K

HL-400KC

120 Volts, 15 Amps

120Volts,20Amps



#### Don't pull the power wire hardly!

#### General technical characteristics

1. Functions processed by microprocessors
2. Temperature adjustable from  $18^{\circ}\text{C}$  to  $60^{\circ}\text{C}$  ( $64^{\circ}\text{F}$  to  $140^{\circ}\text{F}$ )
3. Adjustable dwell time from 0 to 60 minutes
4. Digital temperature sensor
5. Soft touch key
6. Long-live carbon fibre heater

#### Packaging and Individual Panel Information

The sauna comes packaged in 2 boxes:

PLEASE FIND OUT THE SAME NUMBER OF THE CARTON BOX.

FOR EXAMPLE: "NO.001 1 OF 2" FIT "NO.001 2 OF 2" on carton package.

THEN YOU CAN ASSEMBLE OUR SET VERY EASILY.



**7.0 Illustrations**

**Illustration 8.7 - Manual (HL-200K)**



NOTE: PLS DO NOT MIX PACK (MEANS PARTS FROM DIFFERENT BOXES CAN NOT BE INSTALLED TOGETHER, OR EXCHANGED ).

<b>Parts list of a sauna room</b>	
Bottom Panel	Top Panel
Bench Panel	Bench Heater Panel
Front Panel	Left Side Panel
Right Side Panel	Back Panel
Accessory	

Below are pictures of individual panels for the 2-person model. Othe models vary.

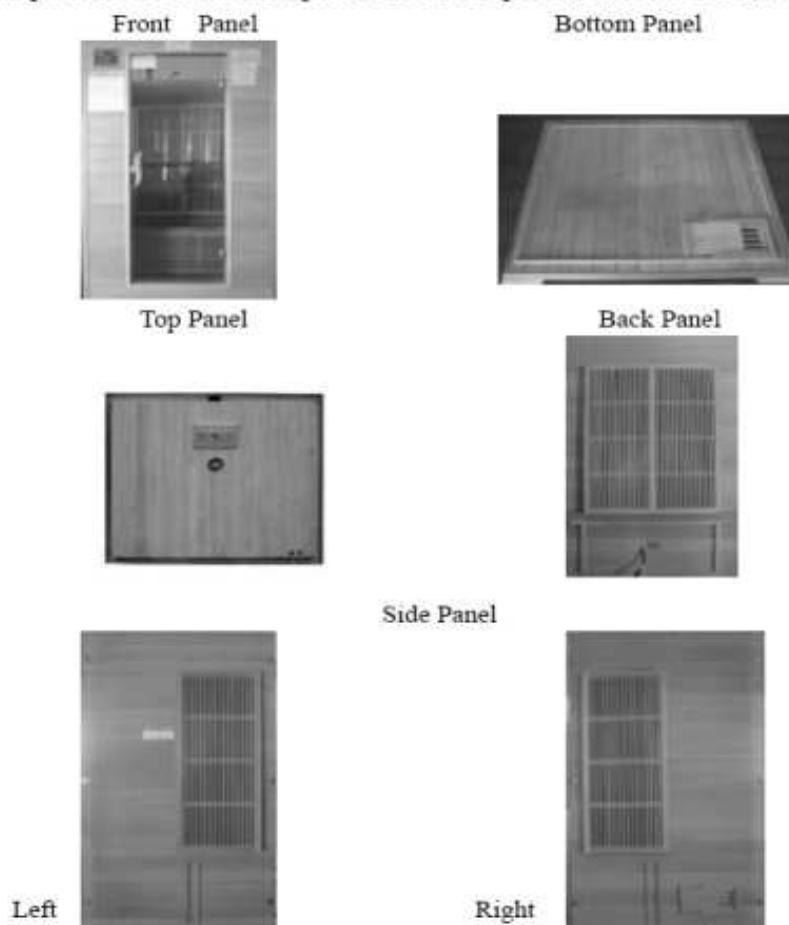

**7.0 Illustrations**

**Illustration 8.8 - Manual (HL-200K)**



Bench Panel



Bench Heater Panel

**WARNING!!!** The receptacle provided by the manufacturer must be installed by a qualified electrician only.

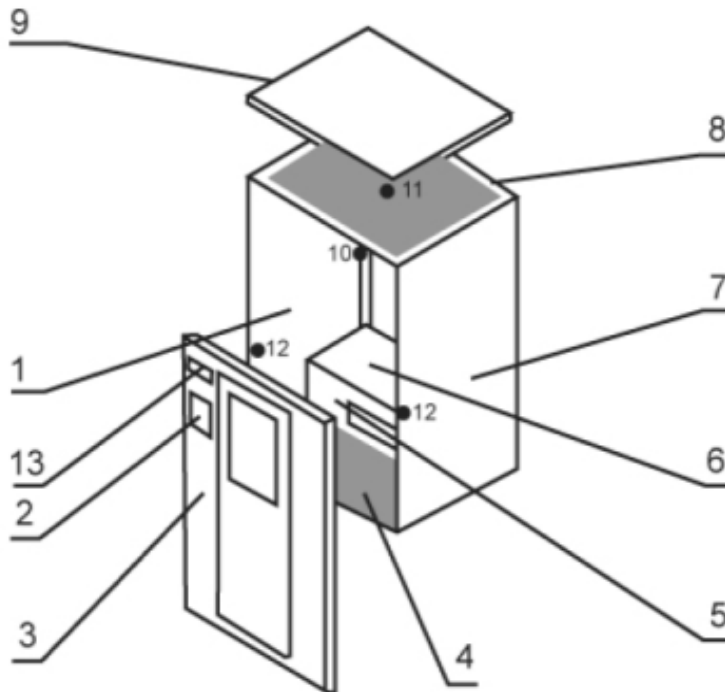

- |                               |                           |                          |
|-------------------------------|---------------------------|--------------------------|
| 1. Left Side Panel            | 2. Digital controll panel | 3. Front Panel           |
| 4. Bottom Panel               | 5. Bench Heater Panel     | 6. Bench Panel           |
| 7. Right Side Panel           | 8. Back Panel             | 9. Top Panel             |
| 10. Oxygen Ionizer (optional) | 11. Light                 | 12. Cup holder           |
|                               |                           | 13. CD Player (optional) |

**Installation Information**

- a. Do not plug any other appliances into the outlet with your sauna.
- b. the sauna should always be placed on a fairly leveled surface.
- c. the sauna must be placed indoors and in a dry area.
- d. Do not spray the exterior with water. If the floor is damp, install a floor separator to keep the sauna high & dry.
- e. Do not store flammable objects or chemical substances near the sauna.

## 7.0 Illustrations

### Illustration 8.9 - Manual (HL-200K)

#### Assembly Instructions

Assembly of the sauna requires at least 2 adults to complete. Please read the instructions thoroughly before and during assembly to ensure proper installation of the unit. If you encounter any problems or have questions during assembly, please feel free to call our Customer Service or local dealers.

#### (1) LOCATION OF SAUNA

When determining a location for your sauna, please keep in mind the following:

1. The Main Power Cord on the sauna must be easily accessible.
2. The location must be dry and leveled.

#### (2) PLACING BOTTOM PANEL

Place the Bottom Panel on the ground and make sure that the "FRONT" sticker is facing the direction where the front of the sauna would be.



#### (3)CONNECTING BACK PANEL TO BOTTOM PANEL

Connect the Back Panel to the Bottom Panel by lining up the Back Panel on the groove of the Bottom Panel. Align buckles on both panels and fasten them if applicable.

Keep in mind that the Back Panel will not have enough support from the buckles alone until the Side Panels have been installed in place.

## 7.0 Illustrations

### Illustration 8.10 - Manual (HL-200K)



Buckle Open



#### (4) CONNECTING SIDE PANELS

Connect the Side Panels to the Bottom

Panels by lining up buckles and fastening them.

1. Each Side Panel has a white label to identify which side it is. The panel with "RIGHT PANEL" label should be placed on the right side when facing the sauna from the front.



#### (5) INSTALLING BENCH HEATER PANEL

Slide down the Bench Heater Panel by lining up its sides with the Vertical Guides on each Side Panel.

1. Bench Heater Panel must be positioned so that the "TOP" sticker is facing up and the heater facing outward.

## 7.0 Illustrations

### Illustration 8.11 - Manual (HL-200K)

2. Be careful not to scratch the Side Panels when positioning the Heater Panel.



### (6) PLUGGING BENCH HEATER CABLE



### (7) INSTALLING BENCH PANEL

Install the Bench Panel by sliding it over the Horizontal Guides on each Side Panel. Be careful not to scratch the Side Panels when doing so.

Make sure to position the Bench so that the "BACK" sticker is facing back, the smooth and finished sides of the Bench are facing up and forward. Then screw the screws of the bench.



**7.0 Illustrations**

**Illustration 8.12 - Manual (HL-200K)**

**(8)CONNECTING LEFT SIDE PANEL AND INSTALLING**

**WOODEN WEB BACK**

Connect the Side Panels to the Bottom Panels by lining up buckles and fastening them.

1.Each Side Panel has a white label to identify which side it is.The Panel with "LEFT PANEL" label should be placed on the left side when facing the sauna from the front.



**(9) CONNECTING FRONT PANEL**

Place the Front Panel onto the recessed area where the "FRONT" sticker is. Align buckles with both Side Panels and secure in place by fastening the buckles.



## 7.0 Illustrations

### Illustration 8.13 - Manual (HL-200K)

#### (10) PLACING TOP PANEL

1. Open Sliding Doors located on the Top Panel.
2. Put the Top Panel on the the assembled panels.  
The Top Panel must be positioned so that the Cables on the Top Panel are in the frontleft corner, right above the stereo.
3. Plug the heater wires through the holes around the Top Panel
4. Gently place the Top Panel onto the rest of the assembled panels. When all four corners are in place, gently push down the Top Panel until it is snugly fit over the rest of the panels.
5. Make sure that the cables around the corners do not get pinched between the panels.



#### (11) POWER SUPPLY CONNECTIONS

All the inside wall's heater elements are pre-wired inside the wall.  
Make Power Supply connections on the Top Panel.

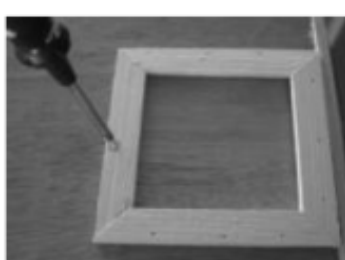

**7.0 Illustrations**

**Illustration 8.14 - Manual (HL-200K)**

**(12)INSTALL THE CONTROL PANEL**

Screw down the cover of the inner control box.

Plug the 6 pin's plug onto the 6 pin's socket of the control panel.

Plug the multi pin's plug onto the multi pin's socket of the control panel.



**(13) INSTALLING CUP HOLDER**



**(14) DOORKNOB INSTALLATION**

Install the Outside Doorknob

1. Align the Outside Doorknob against 2 holes on the outside of the door, hold it at an angle against the door.
2. Insert the Screw into the hole located on the inside of the door. Screw until it is tightly fit.



**7.0 Illustrations**

**Illustration 8.15 - Manual (HL-200K)**

**(15) PLUG YOUR SAUNA INTO THE WALL OUTLET, AND IT'S  
 READY TO BE ENJOYED BY YOU AND YOUR FAMILY!**

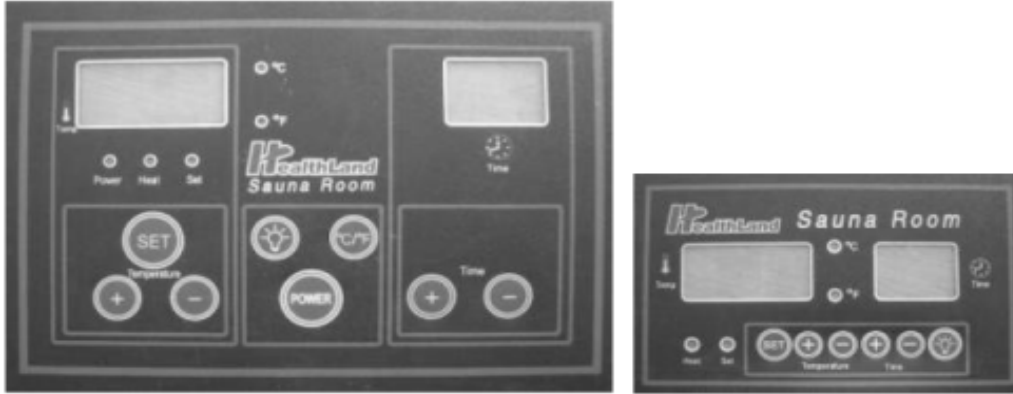

**Digital Control Operating Instructions**

**DIGITAL KEYPAD INSTRUCTIONS:**

<b>SET / TEMP + / TEMP -</b> buttons	Adjust the temperature.
<b>TIME + / -</b> buttons	Adjust the time
<b>POWER</b> button	Power on/off
<b>POWER/HEAT/SET</b> indicator	Status Indicator
<b>LIGHT</b> button	Reading light
<b>°C/°F</b> button	Switching between °C and °F

**Plug in the power cord to the electrical outlet.**

**START-UP**

- Press **POWER** button to turn the power on, **POWER INDICATOR** turns on.
- 2. Press **SET** button to start, If no button is pressed within 10 seconds, the sauna will automatically start with preset settings of 38 minutes and 104°F (factory default).

**B) SET THE TEMPERATURE AND TIME**

- 1. Press **SET** button again, **SET INDICATOR** turns on.
- 2. Press **TEMPERATURE + / TEMPERATURE -** buttons to adjust temperature. Temperature value will increase or decrease by 1 degree at a time. By holding down the **+/-** keys, you can speed up the rate of change. Repress **SET** key again, and now the temperature window displays the present temperature.

## 7.0 Illustrations

### Illustration 8.16 - Manual (HL-200K)

3. Press **TIME + / TIME -** buttons to adjust time. Temperature value will increase or decrease by 1 minute at a time. By holding down the **+/-** keys, you can speed up the rate of change.  
the Time window displays the count down time until - - when heating is stopped.

#### **C) TURN OFF THE SAUNA**

Press **POWER** button again to turn off the sauna.

#### **D) SWITCHING BETWEEN °F AND °C**

When in the state of non-setting mode, press **°F / °C** button, you can alternate between double-digit Centigrade and three-figure Fahrenheit. The **°F** or **°C** indicators will be lit accordingly.

#### **E) READING LIGHT**

Press **LIGHT** button to turn on or off interior light.

#### **F) INSIDE CONTROLLER**

If you choose the inside controller, the operation method is just the same as the outside control panel.

**Note: if leave unused for a long time, please take off the plug.**

## Enjoying your Sauna

### INSTRUCTIONS FOR USE

Review all health and safety instructions. If in doubt as to the advisability of using your infrared sauna, consult with your physician. If you feel light-headed or heat-exhausted during a session, exit the sauna immediately.

1. Set the temperature to a comfortable level, normally, 40-50°C.
2. Allow approximately 8-15 minutes for the sauna to warm up before beginning a session.
3. Perspiration will begin within 6 to 15 minutes after stepping into the unit. We recommend that a sauna session does not exceed 30 minutes.
4. When the temperature reaches the level set on the thermostat, the heaters will turn off and on periodically to maintain the desired temperature level inside of the sauna.
5. The front door/window and/or ceiling vent can be opened at any time to introduce fresh air into the sauna.
6. Infrared's unique property of direct penetration into the body without heating the intervening air in-between allows sauna users to enjoy all of its benefits while the door or window of a sauna is open for ventilation.
7. Always drink plenty of water before, during, and after a sauna session. Doing so will replenish lost fluids from the body through perspiration.
8. Choosing to take a hot shower or bath prior to the sauna session will further promote perspiration. However, dry off thoroughly before going into the sauna because excessive water will stain or warp the wood. A shower after the session is refreshing and rinses perspiration from

## 7.0 Illustrations

### Illustration 8.17 - Manual (HL-200K)

the body.

9. To absorb perspiration and keep the sauna tidy during the session, place a towel on the bench and floor of the sauna. Keep one towel handy to wipe excessive sweat from your body.

#### Tips for Use

- 1) To regulate the temperature inside the sauna during your session, use the roof vent or the door window (by setting it at an angle).
- 2) If you feel the need for more cooling, simply leave the door open until the air around you feels comfortable enough.
- 3) Drink plenty of fluids prior to, during, and after your session.
- 4) If you take a hot/warm shower or bath before your sauna session, you may perspire more. Try it with and without bathing or showering first to determine which way you prefer.
- 5) To utilize the sauna's heat therapy effect, give your hair a hot oil treatment while in the sauna. Put oil or treatment into your hair and wrap it with towel. After the session is over, rinse your hair thoroughly.
- 6) Use at least 2-3 towels. Sit on one towel folded over several times for added cushioning. Put another towel on the floor to absorb extra sweat. A third towel draped over the knees may aid you in comfort and is useful to towel off sweat.
- 7) Be sure to towel off excess sweat during your session to help the body perspire more freely.
- 8) To help relieve sore and tense muscles, massage the affected areas while in sauna to help heal faster.
- 9) Shaving your face or legs with a razor while profusely sweating in a sauna yields an incredibly smooth result without the use of gels or foams.
- 10) Do not eat anything at least an hour before your sauna session. It is better to go in the sauna on an empty stomach. You are more likely to feel uncomfortable sitting in a sauna with a full stomach.
- 11) To make the most out of your sauna session, work your muscles while in the sauna. Stretch your arms and legs, massage your neck, massage your feet, etc.
- 12) You can benefit from the relaxing and soothing effects of a regular sauna session by going to sleep afterwards. The peaceful and relaxed state rendered by a sauna session will help you sleep easier and better.
- 13) At the first sign of cold or flu, increasing your sauna sessions may be beneficial in boosting your immune system and decreasing the reproductive rate of the viruses.
- 14) Consult your physician for the proper treatment for this or any other conditions.
- 15) To treat your ankles and feet more effectively, you must elevate them while inside the sauna. Any area that you wish to achieve a specific deep heating effect in should be moved as close to one of the heaters as feels comfortable.
- 16) After the session is over, do not immediately jump into the shower. Since your body was heated up during the session, it will continue to sweat even after the heaters are off. Sit in the sauna with the door open and let the body sweat a little more while it cools off. After you feel comfortable enough, take a warm shower and finish it off with a cold shower to cool off completely.

## 7.0 Illustrations

### Illustration 8.18 - Manual (HL-200K)

#### Warnings

##### Safety Instructions

1. Read and follow all instructions carefully.
2. When installing and using this electrical equipment, basic safety precautions should always be followed.
3. Do not use the sauna immediately following strenuous exercise. Wait at least 30 minutes to allow the body to cool down completely.

##### Safety precautions

- a. To avoid fire, do not place combustible material on sauna heaters, do not dry clothes or leave any towels in the sauna.
- b. To prevent burns or electric shocks, do not touch or use metal tools on the net cover of the far infrared heater elements. While in the sauna, do not touch the light bulb. If the bulb needs to be changed, switch it off and wait until the sauna is shut off and the bulb is cool
- d. Do not spray water on the far-infrared tube. Do not install shower heads or water spray devices above the sauna heater. This activity may result in electric shock or damage to the heater elements.
- e. Don't install the receptacle inside sauna. Don't install any kind of lock and bolt.
- f. The control is installed on the front panel, please don't press it hardily.
- g. Don't put the power wire and spare part in the hot condition.
- h. Supervise children at all times. Exit immediately if uncomfortable, dizzy, or sleepy, staying too long in a heated area is capable of causing overheating.
- i. Check with a doctor before use if pregnant, in poor health, or under medical care.
- j. Do not use the sauna if you have any of the following conditions:
  - 1) Open wounds
  - 2) Eye diseases
  - 3) Severity sunburns
  - 4) Elderly & weak people, especially those suffering from a disease, pregnant women and infants are prohibited.
  - 5) If suffering from a disease directly related to temperature, seek the advice of a doctor before use.
  - 6) Persons suffering from obesity or with a medical history of heart disease, low or high blood pressure, circulatory system problems, or diabetes should consult a physician prior to using the sauna.
  - 7) Persons using medications should consult a physician before using the sauna since some medications may induce drowsiness while others may affect heart rate, blood pressure, and circulation.
  - 8) Do not place pets in the sauna.
  - 9) Do not use the sauna if you are under the effects of alcohol. The use of alcohol, drugs, or medications prior to or during the sauna session may lead to unconsciousness.

#### Limited Warranty

We warrant the sauna to be free of defects in material and workmanship.

- |                |           |
|----------------|-----------|
| 1) Heaters     | 18 months |
| 2) Workmanship | 18 months |

**7.0 Illustrations**

**Illustration 8.19 - Manual (HL-200K)**

3) Electrical Components 18 months

This warranty extends only to the original retail purchaser of the sauna and terminates upon transfer of ownership. Freight charges to and from the customer are the responsibility of the customer. This includes freight charges for parts shipped to enable the services of your sauna.

This warranty is void if the sauna has been altered, misused, or abused. Such instances shall include operation or maintenance of the sauna in deviation to the published instructions. The warranty extends only to the manufacturing defects and does not cover any damages resulting from mishandling of the product by the owner.

We shall not be liable for the loss of use of the sauna or other incidental or consequential damages. Under no circumstances shall we or any of our representatives be held liable for injury to any persons or damages to any properties. Specifications are subject to change without notice.

For your record, please complete the following information. You will need to refer to these information when calling the manufacturer for customer service.	
Date of Purchase	
Date of delivery	
Model Number	
Serial number	
Dealer Information (Name & Phone)	

Frequently Asked Questions

PS: MAKING SURE SHUT OFF ELECTRICITY BEFORE YOU DOING IT.

1. The controll panel does not work

	Problem	Explanation	Solution
1	The power indicator is not on.	The fuse is broken or the sauna is not plugged in.	Change the fuse or plug in the sauna.
2	The soft keys do not work.	Unplug sauna,wait a minute, and plug back into power source.	

2. The power indicator is not on

Re-press the Over-current protection like the following pictures:



**7.0 Illustrations**

**Illustration 8.20 - Manual (HL-200K)**

3. Reading light does not work

	Problems	Solutions
1	The bulb filament is burned out.	Change the bulb (<40 watt).

Change the bulb

Push down the bulb together with the cover from the top panel, then pull down the plug. Take off the metal pin around the bulb while also take down the broken bulb, next, put a new bulb into the original place, put on pin and install onto the top.

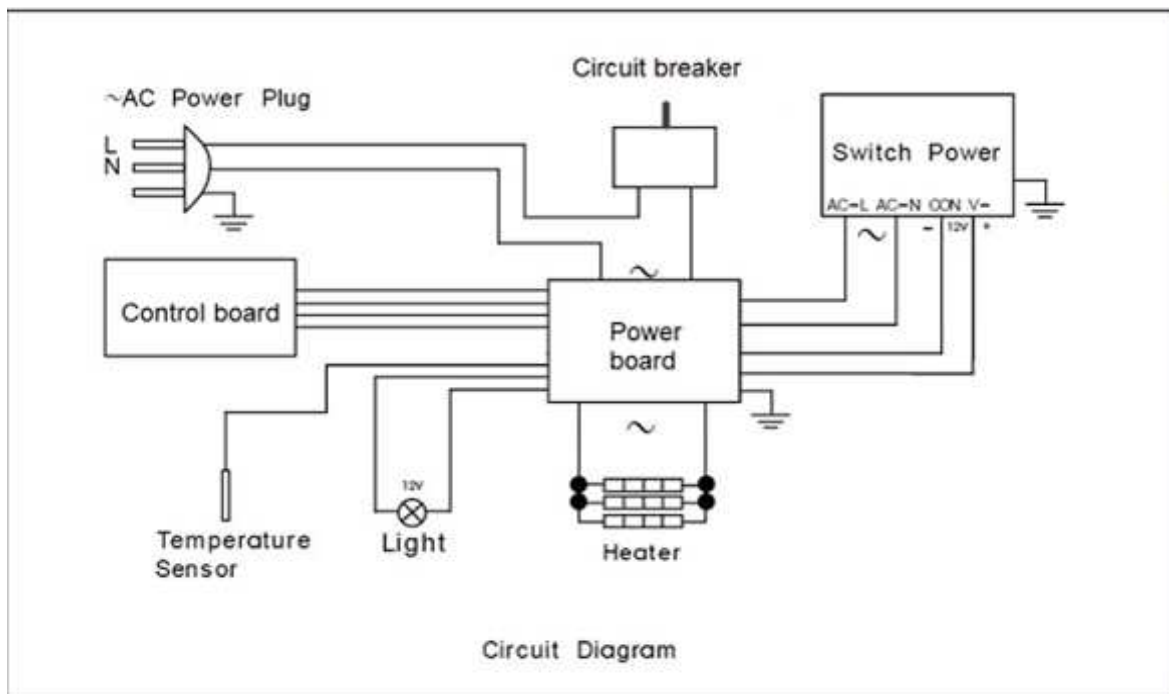

**7.0 Illustrations**

**Illustration 8.21 - Manual (HL-200K)**

3. The heater does not heat up

	Problem	Explanation	Solution
1	Part of the heater does warm up.	The heater is defective	Replace with a new heater
		A portion of the heater is not connected well or is burned out.	Connect them tightly.
2	The entire room does not heat up.	The relay is damaged.	Replace the relay
		The control panel is damaged	Replace the control panel.
		The plug is not plugged in correctly.	Re-plug in the machine.
3	Bench heater does not heat	The bench heater cable is not plugged tightly into the outlet on the Back Panel	Plugged tightly



**Maintenance**

1. Cleaning

a. Clean the faceplate with a wet towel, or clean with a small amount of hand-soap missed with warm water if necessary. Clean the sauna room with a wet cotton towel, dry with a clean dry towel. Do not use benzene, alcohol, or strong cleaning chemicals on sauna.

NOTE: Any chemical that can damage wood material will damage the sauna and the protection layer that is on the wood.

2. Owner's implement a maintenance program for sauna heaters and inspect the sauna heater at the end of the day to ensure the sauna heater is turned off.

## 7.0 Illustrations

### Illustration 8.22 - Manual (HL-200K)

#### **Transportation and storage**

1. Avoid exposure to rain, snow or strong collisions during transport.
2. Do not store in damp environments.

#### Packing list

sauna room	1
owner's manual	1

**7.0 Illustrations**

**Illustration 9 - Detailed number used and position of heater**

Model	Heater Type * Number and NIR*Number					
	Back1 Piece	Back2 Piece	Left Piece	Right Piece	Front Piece	Bench Piece
HL-200K	HL3*2	--	HL3	HL3	HL1*2	HL2
HL-400KC	HL4*2	HL4*2	--	--	HL1*2	HL2*2

Table 2

8.0 Test Summary			
Evaluation Period	2008-12-26 to 2008-01-15		Project No. SH08120370
Sample Rec. Date	12/28/2008	Condition	Prototype
Sample ID.	-		
Test Location	Building No.86, 1198 Qinzhou Road (North), Shanghai 200233, China		
Test Procedure	Testing Lab		
Determination of the result includes consideration of measurement uncertainty from the test equipment and methods. The product was tested as indicated below with results in conformance to the relevant test criteria.			
The following tests were performed:			
Test Description	UL 875 Eighth Edition, rev. March 28, 2008 Clause	CAN/CSA-C22.2 No. 164-M91 rev. 2007 Clause	--
Power Input Test	23	12.2	--
Temperature test	24	12.4	--
Insulation Resistance Test	26	--	--
Dielectric Voltage-withstand Test	27	12.5	--
Abnormal Test	29	12.7	--
Extreme Operating Voltage (Maximum) Test	--	12.8	--
Stability Test	31	12.12	--
Leakage Current	--	12.10	--
Static Loading Test	32	--	--
Performance-Leakage current after humidity	42.2	--	--

Evaluation Period	12 June, 2012 to 18 September, 2012		Project No. SH12060433
Sample Rec. Date	N/A	Condition	Prototype
Sample ID.	N/A		
Test Location	Building No. 86, 1198 Qinzhou Road (North), Shanghai 200233, P. R. China		
Test Procedure	Testing Lab		
Determination of the result includes consideration of measurement uncertainty from the test equipment and methods. The product was tested as indicated below with results in conformance to the relevant test criteria.			
The following tests were performed:			
Test Description	CAN/CSA C22.2 No. 164-M91 reaffirmed 2012 Cl.	UL 875 9th Edition, rev. Nov 16, 2011 Par.	
None			

Evaluation Period	2015.10.9 to 2015.10.13		Project No. 151000201SHA
Sample Rec. Date	N/A	Condition	Prototype
Sample ID.	N/A		
Test Location	Building No. 86, 1198 Qinzhou Road (North), Shanghai 200233, P. R. China		
Test Procedure	Testing Lab		
Determination of the result includes consideration of measurement uncertainty from the test equipment and methods. The product was tested as indicated below with results in conformance to the relevant test criteria.			
The following tests were performed:			
Test Description	CAN/CSA C22.2 No. 164-M91 reaffirmed 2012 Cl.	UL 875 9th Edition, rev. December 17, 2013 Par.	
None			

Evaluation Period	2018.1.17 to 2018.3.14		Project No. 180101310SHA
Sample Rec. Date	N/A	Condition	Prototype
Sample ID.	N/A		
Test Location	Building No. 86, 1198 Qinzhou Road (North), Shanghai 200233, P. R. China		
Test Procedure	Testing Lab		
Determination of the result includes consideration of measurement uncertainty from the test equipment and methods. The product was tested as indicated below with results in conformance to the relevant test criteria.			
The following tests were performed:			

8.0 Test Summary			
Test Description	None	CSA C22.2#164:1991 Ed.1 +G1 Cl.	UL 875:2009 Ed.9+R:26Jul20 17 Par.

Evaluation Period	2020.4.30 to 2020.6.30		Project No.	200403106SHA
Sample Rec. Date	2020.4.30	Condition	Prototype	Sample ID.
Test Location	Building No. 86, 1198 Qinzhou Road (North), Shanghai 200233, P. R. China			
Test Procedure	Testing Lab			

Determination of the result includes consideration of measurement uncertainty from the test equipment and

The following tests were performed:

Test Description	CSA C22.2#164:2018 Ed.2 Clause	UL 875:2009 Ed.9+R:20Sep2 017 Clause
Power Input Test	8.4.2	24
Temperature test	8.4.4	25
Insulation Resistance Test	--	27
Dielectric Voltage-withstand Test	8.4.5	28
Abnormal Test	8.4.7	30
Extreme Operating Voltage (Maximum) Test	8.4.8	--
Leakage Current Test	8.4.10	43.2
Grounding Test	8.2.8	23
Switch and control endurance Test	--	19.1.3

### 8.1 Signatures

A representative sample of the product covered by this report has been evaluated and found to comply with the applicable requirements of the standards indicated in Section 1.0.

Completed by:	Bruce Dai	Reviewed by:	Frank Song
Title:	Certification Engineer	Title:	Technical Reviewer
Signature:	<i>Bruce Dai</i>	Signature:	

**9.0 Correlation Page For Multiple Listings**

The following products, which are identical to those identified in this report except for model number and Listee name, are authorized to bear the ETL label under provisions of the Intertek Multiple Listing Program.

<b>BASIC LISTEE</b>	HEALTHLAND SAUNA EQUIPMENT CO LTD
Address	16 FLOOR, TREASURE BUILDING, NO.29, HUAIHAI WEST ROAD, XUZHOU CITY, JIANGSU PROVINCE
Country	P. R. China
Product	Electric Wooden Dry Sauna

<b>MULTIPLE LISTEE 1</b>	Rocky Mountain Saunas
Address	5400 Ward Rd, Bldg 2, Ste 201, Arvada, CO 80002
Country	United States
Brand Name	Rocky Mountain Saunas

<b>ASSOCIATED MANUFACTURER</b>	All manufacturers shown in Section 1.0
Address	
Country	

MULTIPLE LISTEE 1 MODELS	BASIC LISTEE MODELS
Colorado, Badger	HL-200K
Durango, Rio Grande, Big Bear	HL-400KC

<b>MULTIPLE LISTEE 2</b>	None
Address	
Country	
Brand Name	

<b>ASSOCIATED MANUFACTURER</b>	
Address	
Country	

MULTIPLE LISTEE 2 MODELS	BASIC LISTEE MODELS

<b>MULTIPLE LISTEE 3</b>	None
Address	
Country	
Brand Name	

<b>ASSOCIATED MANUFACTURER</b>	
Address	
Country	

MULTIPLE LISTEE 3 MODELS	BASIC LISTEE MODELS

## 10.0 General Information

The Applicant and Manufacturer have agreed to produce, test and label ETL Listed products in accordance with the requirements of this Report. The Manufacturer has also agreed to notify Intertek and to request authorization prior to using alternate parts, components or materials.

### COMPONENTS

Components used shall be those itemized in this Intertek report covering the product, including any amendments

### LISTING MARK

The ETL Listing mark applied to the products shall either be separable in form, such as labels purchased from Intertek, or on a product nameplate or other media only as specifically authorized by Intertek. Use of the mark is subject to the control of Intertek.

The mark must include the following four items:

- 1) applicable country identifiers "US" and/or "C" or "US", "C" and "EU"
- 2) the word "Listed" or "Classified" or "Recognized Component" (whichever is appropriate)
- 3) a control number issued by Intertek
- 4) a product descriptor that identifies the standards used for certification. Example:

**For US standards**, the words, "Conforms to" shall appear with the standard number along with the word, "Standard" or "Std." Example: "Conforms to ANSI/UL Std. XX."

**For Canadian standards**, the words "Certified to CAN/CSA Standard CXX No. XX." shall be used, or abbreviated, "Cert. to CAN/CSA Std. CXX No. XX."

Can be used together when both standards are used.

**Note: A facsimile must be submitted to Intertek, Attn: Follow-up Services for approval prior to use.**

The facsimile need not have a control number. A control number will be issued **after signed Certification Agreements** have been received by the Follow-up Services office, approval of the facsimile of your proposed Listing Mark, satisfactory completion of the Listing Report, and scheduling of a factory assessment in your facility.

### MANUFACTURING AND PRODUCTION TESTS

Manufacturing and Production Tests shall be performed as required in this Report.

### FOLLOW-UP SERVICE

Periodic unannounced audits of the manufacturing facility (and any locations authorized to apply the mark) shall be scheduled by Intertek. An audit report shall be issued after each visit. Special attention will be given to the following:

1. Conformance of the manufactured product to the descriptions in this Report.
2. Conformance of the use of the ETL mark with the requirements of this Report and the Certification Agreement.
3. Manufacturing changes.
4. Performance of specified Manufacturing and Production Tests.

In the event that the Intertek representative identifies non-conformance(s) to any provision of this Report, the Applicant shall take one or more of the following actions:

1. Correct the non-conformance.
2. Remove the ETL Mark from non-conforming product.
3. Contact the issuing product safety evaluation center for instructions.

### 10.1 Evaluation of Unlisted Components

Because Unlisted Components are uncontrolled, and they do not fall under a third party follow up program, Intertek may require these components to be tested and/or evaluated at least once annually, more often for certain components, as part of the independent certification process. The Unlisted Components in Section 5.0 require testing and/or evaluation as indicated.

**Note to Intertek Follow Up Inspector: The Component Evaluation Center, CEC, will notify you in writing when these components must be selected and sent to the CEC for re-evaluation**

Ship the samples to:  
Intertek Testing Services Shanghai Limited  
Component Evaluation Center  
Building No. 86, 1198 Qinzhou Road (North)  
Shanghai 200233, China  
Attn: Ms. Angela Han

Sample Disposition: Due to the destructive nature of the testing, all samples will be discarded at the conclusion of testing unless, the manufacturer specifically requests the return of the samples. The request for return must accompany the initial component shipment.

**11.0 Manufacturing and Production Tests**

The manufacturer agrees to conduct the following Manufacturing and Production Tests as specified:

**Required Tests**

Dielectric Voltage Withstand Test , Grounding Continuity Test

**11.1 Dielectric Voltage Withstand Test**

Method

Each appliance shall withstand without dielectric breakdown, as a routine production-line test, the application of a 40 – 70 hertz potential between the primary wiring, including connected components, and accessible dead-metal. The test potential is to be:

- a) 1200 volts for an appliance rated 250 volts or less.
- b) 120 percent of the sum of 1000 volts plus twice the rated voltage for an appliance rated for more than 250 volts.

Test Equipment

The test equipment shall incorporate a transformer with an essentially sinusoidal output, a means to indicate the applied test potential, and an audible and/or visual indicator of dielectric breakdown

The test equipment shall incorporate a voltmeter in the output circuit to indicate directly the applied test potential if the rated output of the test equipment is less than 500VA.

If the rated output of the test equipment is 500VA or more, the applied test potential may be indicated by either: 1 - a voltmeter in the primary circuit; 2 - a selector switch marked to indicate the test potential; or 3 - a marking in a readily visible location to indicate the test potential for test equipment having a single test potential output. In cases 2 and 3, the test equipment shall include a lamp or other visual means to indicate that the test potential is present at the test equipment output. All test equipment shall be maintained in current calibration.

**Products Requiring Dielectric Voltage Withstand Test:**

<u>Product</u>	<u>Test Voltage</u>	<u>Test Time</u>
All products covered by this Report.	1000V	60 s
	or	
	1200V	1 s

## **11.2 Grounding Continuity Test**

### Method

Each appliance that has a power-supply cord having a grounding conductor shall be tested, as a routine production-line test, to ensure grounding continuity between the grounding blade of the attachment plug and the Only a single test is required to be performed when the accessible metal selected is conductively connected by design to all other accessible metal.

An indicating device such as an ohmmeter, a battery-and-buzzer combination, or the like may be used to determine compliance with the grounding continuity requirement.

### **Products Requiring Grounding Continuity Test:**

All products covered by this Report.

12.0 Revision Summary				
The following changes are in compliance with the declaration of Section 8.1:				
Date/ Proj # Site ID	Project Handler/ Reviewer	Section	Item	Description of Change
R1 Sep 18, 2012 SH12060433 SHA	Kam Lu/ Michael Y Ye	—	—	This revision of report is to update standard to the latest version.
		1.0	—	Update UL standarf from UL 875 Eighth Edition, rev. March 28, 2008 to UL 875 9th Edition, rev. November 16, 2011; Update CSA standard from CAN/CSA-C22.2 No.164-M91 dated September 1991, Reaffirmed 2007 to CAN/CSA-C22.2 No.164-M91 dated September 1991, Reaffirmed 2012
		1.0	—	Update Contact from Mr. Yongjie Hu to Mr. Mingtao Zhao Update Email from healthland8@healthlandsauna.com to info@healthlandsauna.com
		3.0	—	Update photo 13, 14, 20 related to circuit breaker and terminal box
		4.0	—	Change item 27 from over-current protector to circuit breaker. Change item 34 from quick connector to terminal block Add item 37 terminal box
		5.0	—	Add UL499 to Heater component standard
		7.0	—	Update new intertek logo of all nameplates
		8.0	—	Add new test summary
		12.0	—	Update revsion summary
13-Oct-2015	Kam Lu	—	—	This revision of report is to update UL standard to latest version
R2 151000201S HA	Michael Y. Ye	1.0	—	Update UL standard from "UL 875 9th Edition, rev. November 16, 2011" to "UL 875 9th Edition, rev. December 17, 2013"
		8.0	—	Add new test summary
		12.0	—	Update revsion summary
14-Mar-2018	Bruce Dai	1.0	—	Updated UL Standard from "Electric Dry-Bath Heaters; UL 875 9th Edition, rev. December 17, 2013" to "Standard for Electric Dry-Bath Heaters[UL 875:2009Ed.9+R:26Jul2017]" Updated CSA Standard from "Electric Sauna Heating Equipment; CAN/CSA-C22.2 No.164-M91 dated September 1991, Reaffirmed 2012" to "Electric Sauna Heating Equipment (R2016) [CSA C22.2#164:1991 Ed.1 +G1]"
180101310SHA	Michael Y. Ye	2.0	—	Added other ratings
		3.0	13	Updated Photo 13
		3.0	14	Updated Photo 14
		4.0	4	Updated Technical data from "Flame spread rating 70" to "Flame spread rating 50", added Intertek Test Report 180226004SHF-BP-1.
		4.0	9	Updated model from "DJ-006" to "DJ-005B"
		4.0	14	Updated Manufacturer from "Permacel" to "NITTO INC"
		4.0	24	Updated model from "AG-11, AG-13.5" to "EG-11, EG-13.5"
		4.0	25	Updated model from "JFH01" to "JFG01"
		4.0	27	Updated Manufacturer from "TAISHIBA ELECTRONICS (KUNSHAN) CO LTD" to "QICHENG ELECTRICAL EQUIPMENT CO LTD" Updated model from "TKM2-EB30" to "CBB260"
		4.0	31	Updated Manufacturer from "HIGHTECH ELECTRONICS CO LTD" to "CHANGZHOU CHUANGLIAN POWER SUPPLY TECHNOLOGY CORPORATION"

12.0 Revision Summary				
The following changes are in compliance with the declaration of Section 8.1:				
Date/ Proj # Site ID	Project Handler/ Reviewer	Section	Item	Description of Change
		4.0	36	Updated Manufacturer from "KAI SUH SUH ENTERPRISE CO LTD" to "DONGGUAN JIAN HUI METAL & PLASTIC PARTS CO LTD" Updated model from "J751-BS" to "J610"
		7.0	1	Updated the description of CSA Standard of marking to comply with GSSQ
		8.0	—	Updated test summary
9-Sep-2019	Bruce Dai	4.0	11	Updated Name from "Pressure-sensitive system " to "Marking Label"
190802721S HA	Hyden Li	6.0	8	Updated Markings from "Refer to item 11 of section 4 and illustration 1 of section 7 for details." to "Refer to item 11 of section 4 and illustration 1.1, 1.2 of section 7 for details. "
		6.0	9	Upaded Cautionary Markings from "Refer to marking pages for details" to "Refer to illustration 3.1, 3.2 of section 7 for details"
		6.0	10	Updated Installation, Operating and Safety Instructions from "Refer to illustration and manual pages for details." to "Refer to illustration 8.1 to illustration 8.22 of section 7 for details."
		7.0	1.2	Added related new nameplate for Multiple Listee 1, Multiple Listee 1
		9.0	1	Added Mutiple Listee 1: Rocky Mountain Saunas Address: 5400 Ward Rd, Bldg 2, Ste 201, Arvada, CO 80002 Counry: United States Brand: Rocky Mountain Saunas  Added MULTIPLE LISTEE 1 MODELS: Colorado, Badger, Durango, Rio Grande, Big Bear Basic Listee models: HL-200K, HL-400KC
30-Jun-2020	Bruce Dai <i>Bruce Dai</i>	1.0	—	Updated UL Standard from "Electric Dry-Bath Heaters[UL 875:2009Ed.9+R:26Jul2017]" to "Electric Dry-Bath Heaters [UL 875:2009 Ed.+R:20Sep2017]"  Updated CSA Standard from"Electric Sauna Heating Equipment (R2016) [CSA C22.2#164:1991 Ed.1 +G1]" to "Electric Sauna Heating Equipment [CSA C22.2#164:2018 Ed.2]"
R5 200403106SHA	Frank Song <i>Frank Song</i>	3.0	1	Updated Photo 1
		3.0	2	Updated Photo 2
		3.0	4	Updated Photo 4
		3.0	5	Updated Photo 5
		3.0	6	Updated Photo 6
		3.0	7	Updated Photo 7
		3.0	8	Updated Photo 8
		3.0	10	Updated Photo 10
		3.0	11	Updated Photo 11
		3.0	12	Updated Photo 12
		3.0	13	Updated Photo 13
		3.0	14	Updated Photo 14
		3.0	20	Updated Photo 20
		3.0	24	Added Photo 24

<b>12.0 Revision Summary</b>				
The following changes are in compliance with the declaration of Section 8.1:				
Date/ Proj # Site ID	Project Handler/ Reviewer	Section	Item	Description of Change
		3.0	25	Added Photo 25
		4.0	1	Corrected UL number from "E310740" to "E309871"
		4.0	2	Updated Power Plug from type "YY-3" and "YY-3H" manufactured by NINGBO YUNHUAN ELECTRONICS GROUP CORP to type "LM-3" manufactured by SHAOXING LIMA ELECTRIC CO LTD and type "JT2-3I" manufactured by ZHEJIANG JINTING NUCLEAR CABLE CO LTD
		4.0	7	Updated LED from "MR16" manufactured by JinMei Electronic Lighting Illumination CO.,LTD to "YCG02" manufactured by XUZHOU XINGETE ELECTRIC TECHNOLOGY CO., LTD
		4.0	8	Updated Coupler from "KE-06" manufactured by KENIC ELECTRIC MFG CO LTD to "LM-3ZP" manufactured by SHAOXING LIMA ELECTRIC CO LTD
		4.0	9	Updated type from "DJ-005B" to "LM-3ZR" Updated manufacturer from "SHENZHEN DONG JU WIRE & CABLE CO LTD" to "SHAOXING LIMA ELECTRIC CO LTD"
		4.0	12	Updated type from 1/4"d to 3/8"d
		4.0	14	Updated Insulated Tape from type "P-212" manufactured by NITTO INC to type "1069" manufactured by 3M COMPANY ELECTRICAL MARKETS DIV (EMD)
		4.0	16-19	Updated manufacturer from "SJunyue electron(Kunshan) Co., Ltd" to "Changzhou Zadao Electric Co., Ltd."
		4.0	23	Updated manufacturer from SHANGHAI JIANGPENG WIRE & CABLE CO LTD and WUXI HUACHENG CABLE CO LTD to JIANGYIN ZHIJUN APPLIANCE ELECTRIC CABLE & WIRE CO LTD
		4.0	29	Updated Relay for Heater from type "LR SSR-DA" manufactured by ZHEJIANG LIERD RELAYS ENTERPRISE CO LTD to type "HHC67E-1H-12VDC" manufactured by XINLING ELECTRICAL CO LTD CHINA
		4.0	30	Updated name from Lamp Switch to Relay for LED
		4.0	31	Updated Power Switching supply from type "HTS-60F-12" manufactured by CHANGZHOU CHUANGLIAN POWER SUPPLY TECHNOLOGY CORPORATION and "S120S500C7" manufactured by SHENZHEN SUNSHENG INDUSTRY CO LTD to type "A-75FAM-12" and "A-150FAO-12" manufactured by CHANGZHOU CHUANGLIAN POWER SUPPLY TECHNOLOGY CORPORATION
		7.0	4.1	Updated Electrical Schematic
		7.0	4.2	Updated PCB Layout
		7.0	6	Updated Ventilation
		7.0	9	Added Illustration 9
		8.0	—	Updated test summary